

Adirondack chair

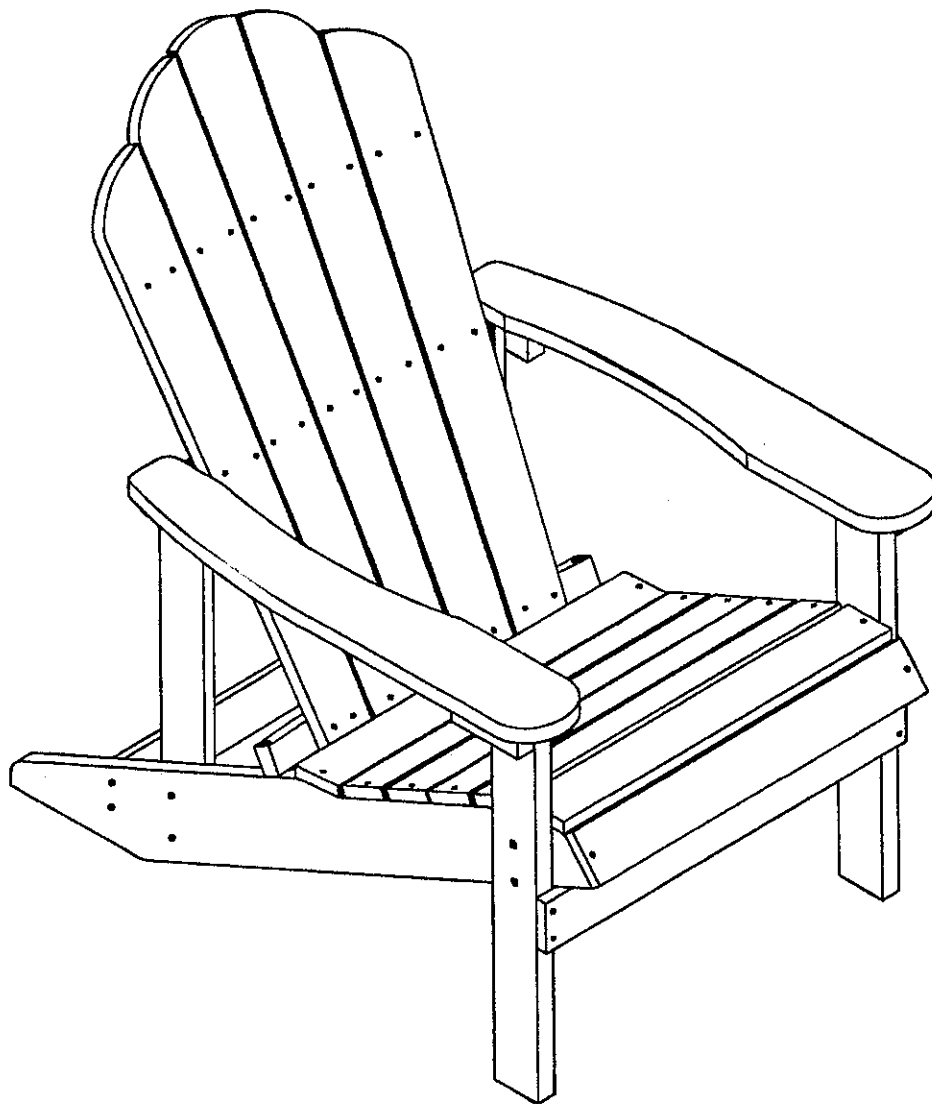

Made in China

User Manual

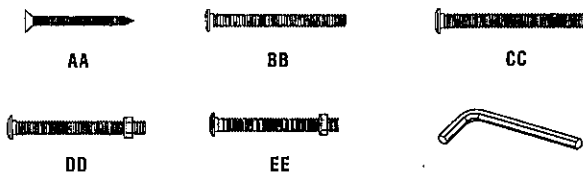

Part	Description	Quantity
AA	Screw (3.5x40)	6
BB	Bolt (M6x60)	2
CC	Bolt (M6x70)	2
DD	Bolt (M6x60)	6
EE	Bolt (M6x45)	4

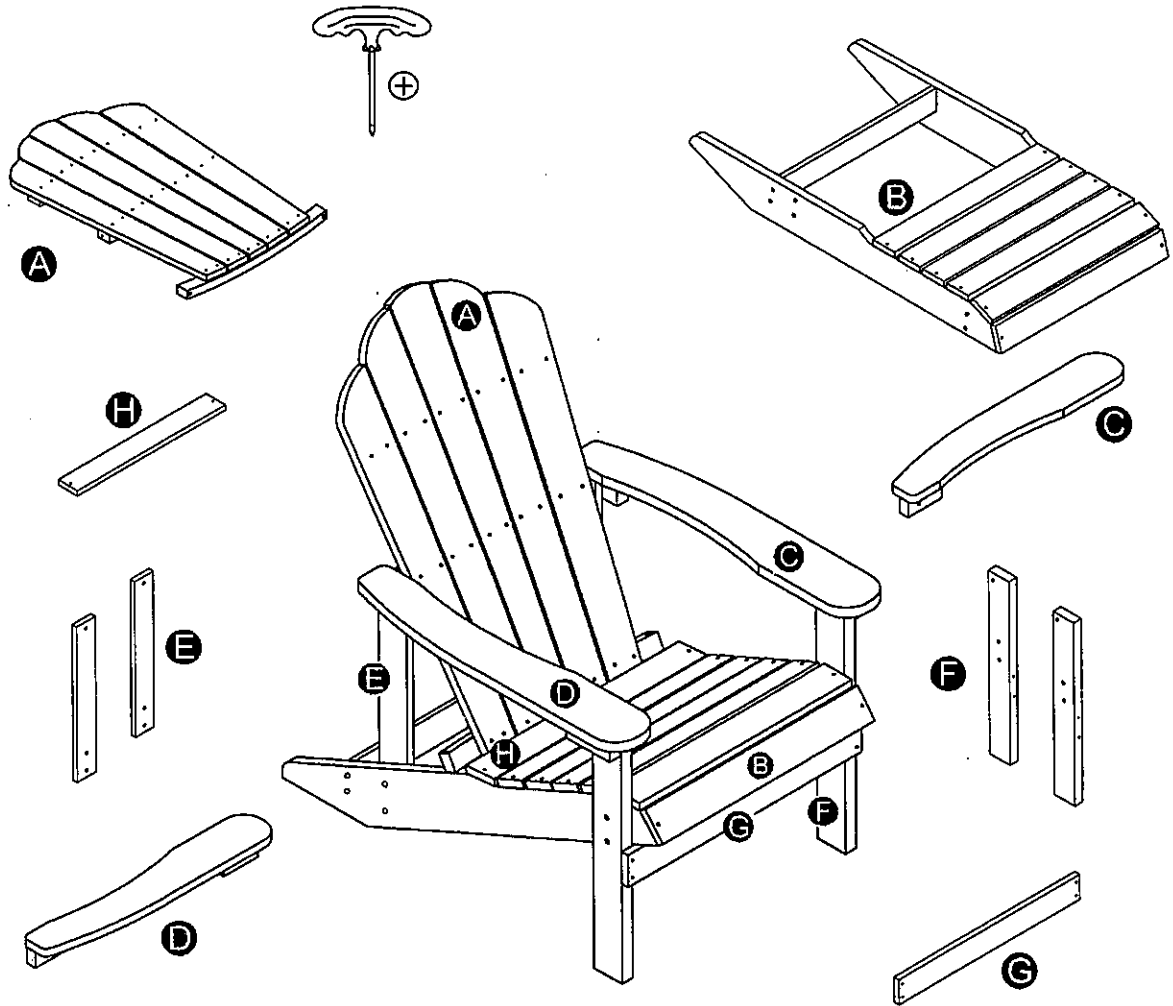

Part	Description	Quantity
A	Back	1
B	Seat	1
C	Left armrest	1
D	Right armrest	1
E	Vertical Back Support	2

Part	Description	Quantity
F	Front Legs	2
G	Front Leg Cross Beam	1
H	Rear Seat Slat	1

***Note: DO NOT TIGHTEN ANY BOLTS BEFORE THE UNIT PUT TOGETHER.**

※ご注意：ユニットを組み立てる前にボルトをきつく締めないでください。

STEP 1 Attaching the rear seat slat

Attaching the rear seat slat (H) to the seat (B) with screws (AA)

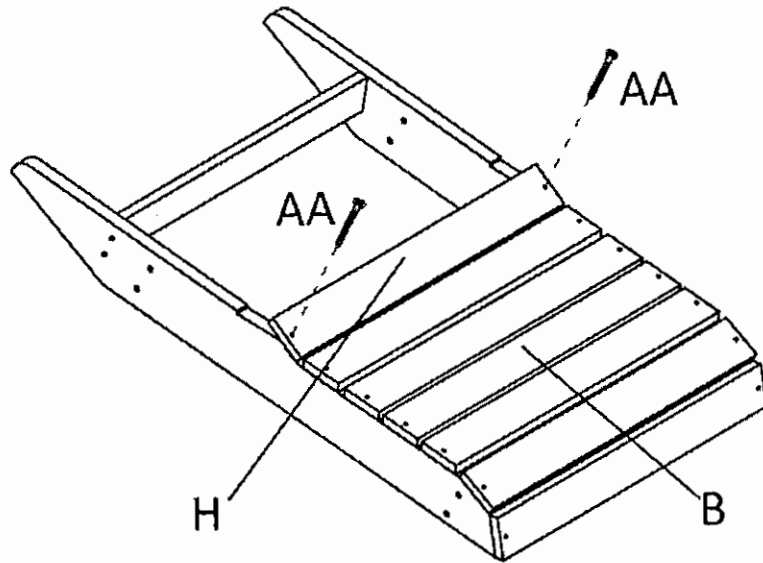

STEP 2 Attaching the front legs

Attaching the front legs (F) to the seat (B) with bolts (DD)

Attaching the back supports (E) to the seat (B) with bolts (EE)

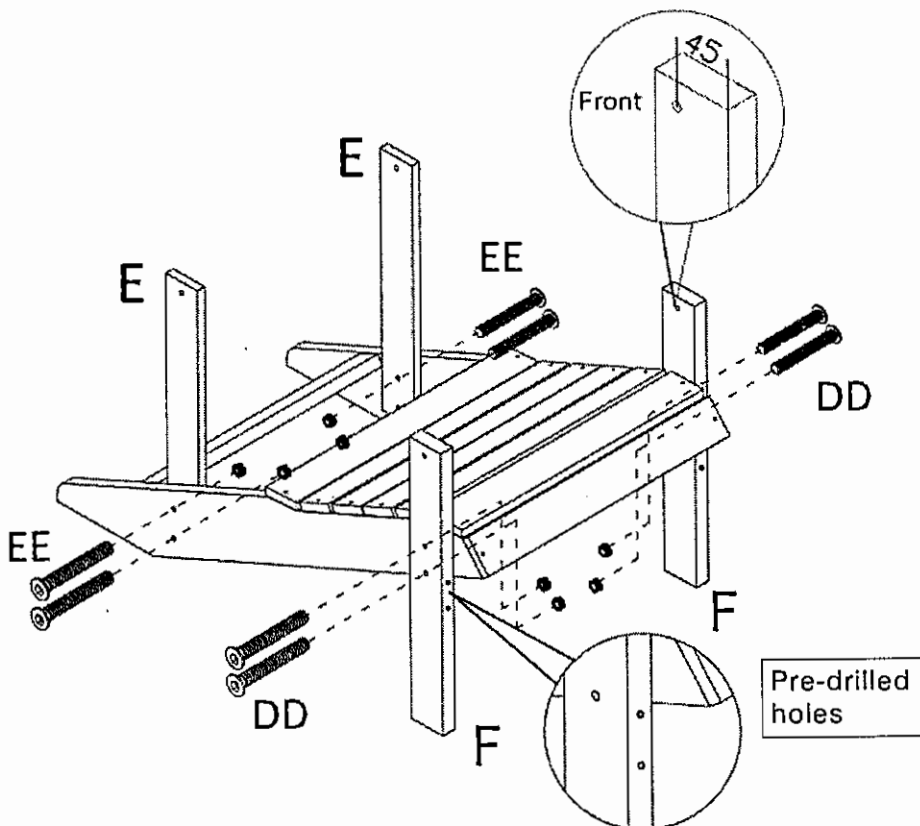

STEP 3 Attaching the armrest

Attaching the armrest (C) and (D) to the legs (F) with bolts (DD)

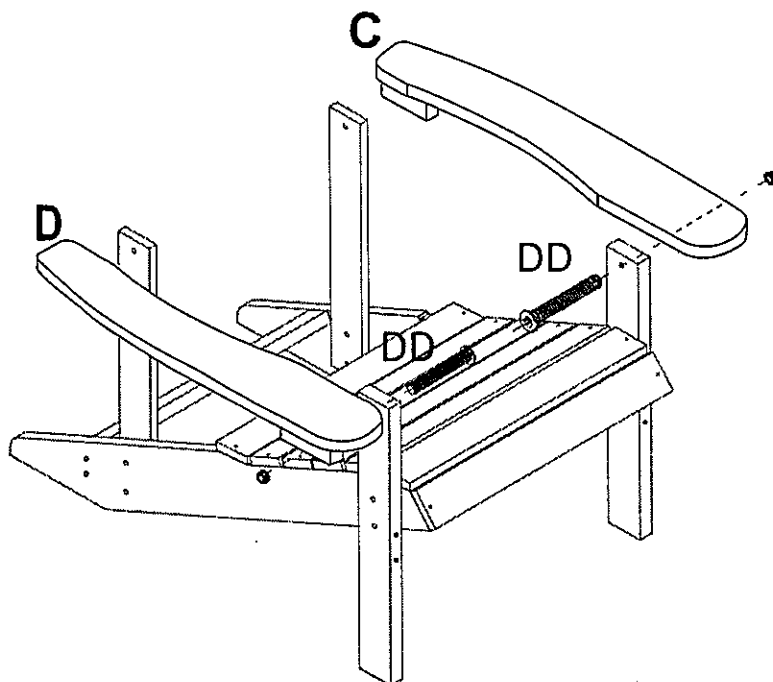

STEP 4 Attaching the back

Attaching the back (A) to the seat (B) with bolts (BB)

Attaching the armrest (C) and (D) to the back (A) with bolts (CC)

※1、2の穴位置が合わない場合は、全てのボルトを緩めてください。

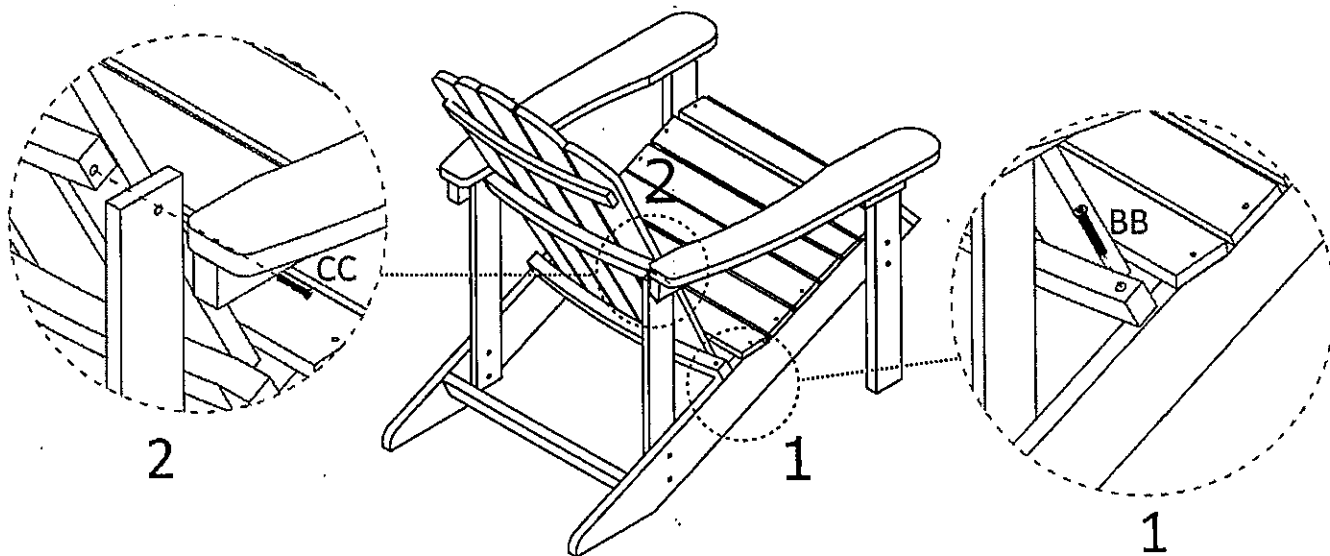

STEP 5 Attaching the cross beam

Attaching the cross beam (G) to the front legs (F) with screws (AA)

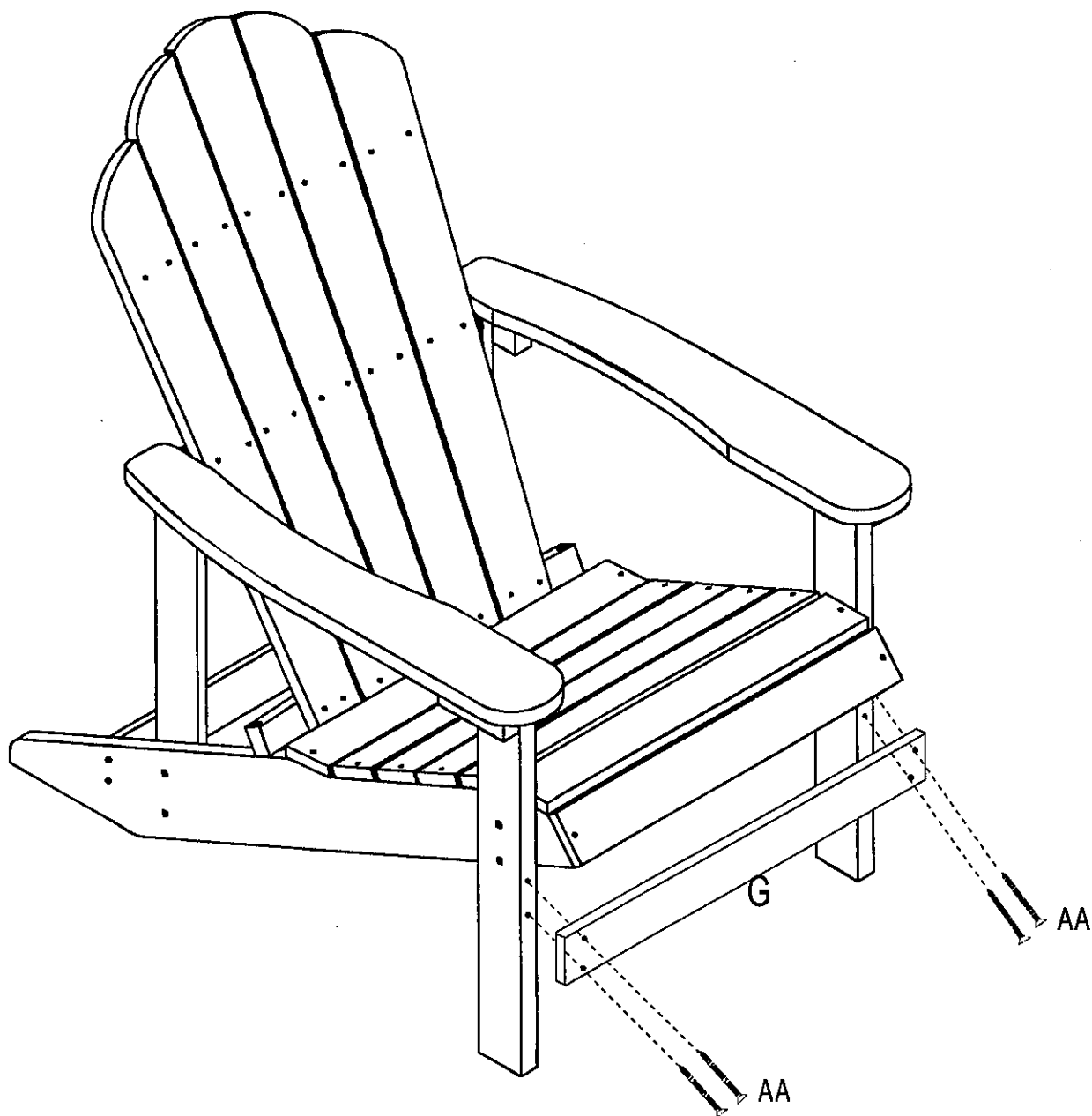

パーツが組み終わったら、全てのボルトを増し締めしてください。