

KETER

Create amazing spaces™

DARWIN 6x4

USER MANUAL | MODE D'EMPLOI | MANUAL DEL USUARIO | GEBRAUCHSANLEITUNG |
GEBRUIKSHANDLEIDING | MANUALE PER L'U TENTE | MANUAL DO UTILIZADORWWW.KETER.COM

US, Canada: (EN/FR)
keter.com/en-us/contact-us.html
Tel: +1-888-374-4262
Email: NA_CS@keter.com

UK
Tel: +44-121-506-0008, CSUK@keter.com
Mon - Fri | 8am - 4pm

For other European countries see the Last page
Pour les autres pays d'Europe, voir la dernière page
Para otros países europeos vea la última página

0183 105 1-03514

WARRANTY ACTIVATION

Thank you for your purchase of the Keter shed.
In order to activate your warranty, please log on to our website and fill in the form under warranty activation.

keter.com/en/warrant-activation

SITE PREPARATION | PRÉPARATION DU SITE | PREPARACIÓN DEL LUGAR | VORBEREITUNG DES AUFSTELLUNGORTES |
 YOORBEREIDING VAN HET TERREIN | PREPARAZIONE DEL LUOGO DI ASSEMBLAGGIO | PREPARAÇÃO DO LOCAL

Level the ground surface | Nivelez la surface du sol | Nivele la superficie del suelo | Ebenen Sie die Bodenoberfläche
 | Maak de bodem vlak | Livellare la superficie del terreno | Nivele a superfície do solo



Recommendation: Construct a wooden or concrete base as a foundation | Recommandation: fabriquez une base en bois ou en béton en guise de fondation | Recomendación: construya una base de madera o de cemento a modo de cimiento |
 Empfehlung: Bauen Sie als Fundament eine Grundfläche aus Holz oder Beton | Aanbeveling: maak een houten of betonnen
 ondergrond als fundering | Raccomandazione: Costruire una base di legno o di cemento come fondamenta | Recomendação:
 Construa uma base de madeira ou de cimento como fundação

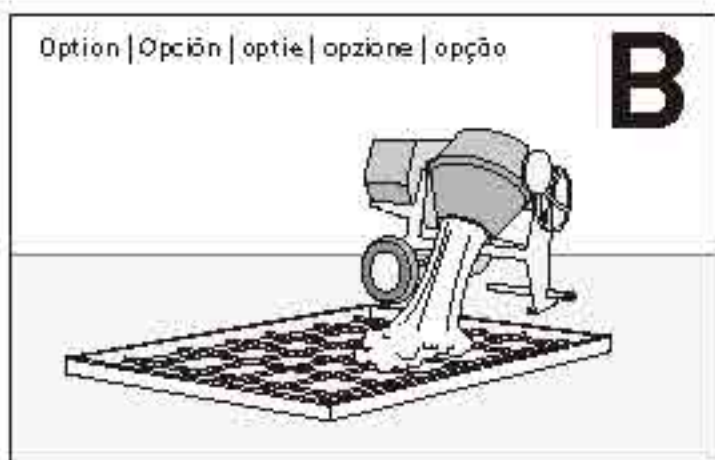
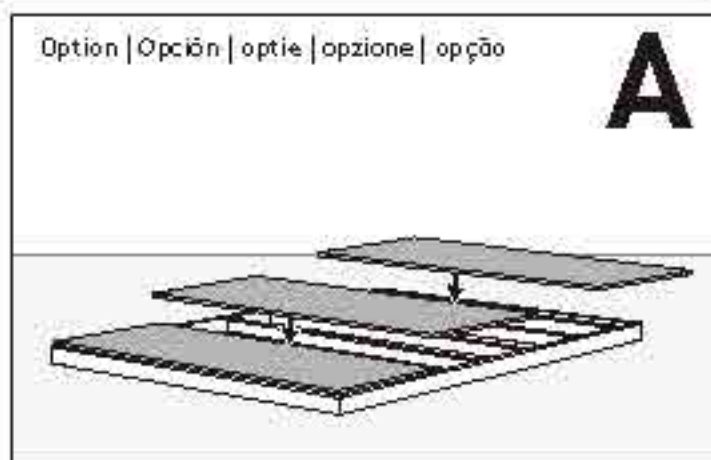

For external access during assembly, make sure to leave enough room around the outside of the shed assembly site.

Pour un accès externe au cours du montage, veillez à laisser suffisamment de place autour du site de montage.

Para tener un acceso exterior durante el montaje, asegúrese de dejar suficiente espacio alrededor del lugar de montaje del cobertizo.

Lassen Sie am Aufstellungsort außerhalb des Schuppens ausreichend Platz, so dass Sie während des Aufbaus von außen Zugang zum Schuppen haben.

Om tijdens de montage aan de buitenkant van het schuurtje te kunnen werken, moet u ervoor zorgen dat u genoeg ruimte laat aan de buitenkant van de montageplaats.

Per l'accesso esterno durante il montaggio, assicurati di lasciare abbastanza spazio intorno alla parte esterna del luogo di montaggio del deposito attrezzi.

Para ter acesso externo durante a montagem certifique-se de que deixa espaço suficiente em redor do exterior do local de montagem do abrigo.

External floor measurements are: | Les mesures externes de la étage sont: | Las medidas del suelo externo son: | Die Außen-Bodenmaße betragen: | De afmetingen van de externe vloer zijn: | Le dimensioni esterne del pavimento sono: | As medidas externas do chão são:

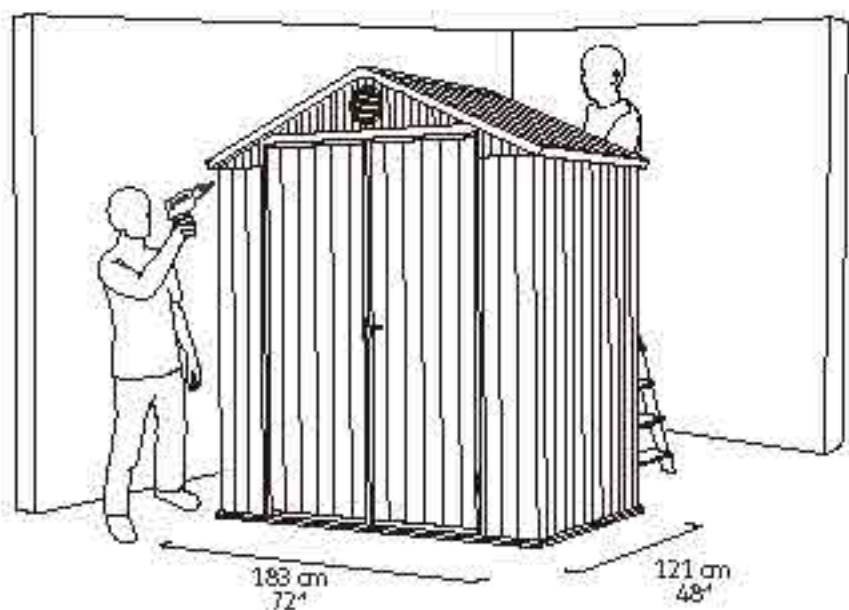

BEFORE STARTING ASSEMBLY | AVANT DE COMMENCER LE MONTAGE | ANTES DE EMPEZAR EL ARMADO | VOR MONTAGEBEGINN | YOORDAT U BEGINT TE MONTEREN | PRIMA DI INIZIARE L'ASSEMBLAGGIO | ANTES DE INICIAR A MONTAGEM

Read the care and safety guidelines at the end of this manual | Check to ensure that there are no missing or damaged parts BEFORE starting or arranging assembly | Remove all parts from the package(s) and spread them out on a clean work surface | Review all assembly instructions | Assemble all the parts according to the directions in this manual. Do not skip any steps.

Lisez les instructions de précaution et de sécurité à la fin de ce manuel | Assurez-vous qu'il n'y a pas de pièces manquantes ou endommagées AVANT de commencer ou d'organiser l'assemblage | Retirez toutes les pièces du/des paquet(s) et étalez-les sur une surface de travail propre | Lisez toutes les instructions de montage | Assemblez toutes les pièces selon les instructions de ce manuel. Ne sautez aucune étape.

Lea las instrucciones de precauciones y seguridad que están al final de este manual | Asegúrese de que no faltan piezas ni están dañadas ANTES de comenzar o disponer el montaje | Saque todas las piezas del paquete o paquetes y póngalas sobre una superficie de trabajo limpia | Revise todas las instrucciones de montaje | Monte todas las piezas según las instrucciones de este manual. No se saltee ningún paso.

Lesen Sie die Sicherheitsrichtlinien am Ende des Benutzerhandbuchs durch | Prüfen Sie bitte VOR dem Zusammenbau, dass keine Teile beschädigt sind oder fehlen | Nehmen Sie alle Teile aus der Verpackung und breiten Sie sie auf einer sauberen Arbeitsfläche aus | Gehen Sie noch einmal die komplette Aufbauanleitung durch | Bauen Sie alle Teile entsprechend der Anleitung in diesem Handbuch zusammen. Lassen Sie dabei keinen Arbeitsschritt aus.

Lees de richtlijnen voor zorg en veiligheid achterin deze handleiding | Controleer dat er geen onderdelen mankeren, of beschadigd zijn, VOORDAT u met de montage begint | Haal alle onderdelen uit het pakket (of uit de pakketten) en leg ze open op een schoon werkoppervlak | Bekijk alle montagehandleidingen | Monteer alle onderdelen volgens de aanwijzingen van deze handleiding. Sla geen stappen over.

Leggere le linee guida di assistenza e sicurezza alla fine di questo manuale | Assicurarsi che non ci siano parti mancanti o danneggiate PRIMA di iniziare l'assemblaggio | Estrarre tutti i componenti dall'imballo e posizionarli su una superficie di lavoro pulita | Consultare tutte le istruzioni di montaggio | Assemblare tutti i componenti secondo le istruzioni contenute nel manuale. Non saltare nessuna fase.

Leia as diretrizes de cuidados e segurança que constam da parte final deste manual | Verifique para se assegurar de que não há peças em falta ou danificadas ANTES de começar a preparar a montagem | Retire todas as peças da embalagem e espalhe-as numa superfície de trabalho limpa | Reveja todas as instruções de montagem | Monte todas as peças de acordo com as instruções do manual. Não salte quaisquer passos.

REQUIRED TOOLS | OUTILS EXIGÉS | HERRAMIENTAS NECESARIAS | BENÖTIGTE WERKZEUGE | BENODIGD GEREEDSCHAP | ATTREZZATURA OCCORRENTE | FERRAMENTAS NECESSÁRIAS

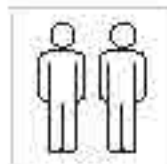
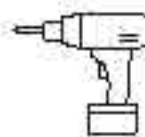
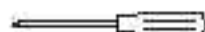
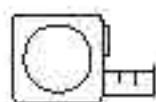

ASSEMBLY REQUIRES TWO PEOPLE | LE MONTAGE DOIT ÊTRE EFFECTUÉ PAR DEUX PERSONNES | SE NECESITAN DOS PERSONAS PARA ARMARLO | ZWEI PERSONEN ZUR MONTAGE NOTWENDIG | MONTAGE VEREIST TWEE PERSONEN | L'ASSEMBLAGGIO RICHIEDE DUE PERSONE | A MONTAGEM EXIGE DUAS PESSOAS

Packaging may contain some additional small parts for use as spare parts | L'emballage peut contenir de petites pièces supplémentaires à utiliser comme pièces de rechange | El envoltorio puede contener algunas piezas pequeñas adicionales que se pueden utilizar como repuestos | In der Verpackung können kleine Zusatzteile enthalten sein, die als Ersatzteile genutzt werden können | De verpakking kan een aantal kleine extra onderdelen bevatten, die als reserveonderdeel gebruikt kunnen worden | L'imballo potrebbe contenere piccoli componenti supplementari da utilizzare come ricambiotici | A embalagem pode conter algumas pequenas peças adicionais para utilização como peças de reposição

NOTE: Due to variations in production, the actual assembled size may vary slightly from the specified dimensions.

REMARQUE: En raison de variantes dans la production, la taille de montage réelle peut différer quelque peu des dimensions indiquées.

NOTA: debido a las variaciones en la producción, el tamaño real al montarlo puede variar ligeramente con respecto a las dimensiones especificadas.

BITTE BEACHTEN: Aufgrund von Abweichungen in der Herstellung kann die tatsächliche Größe leicht von den angegebenen Maßen abweichen.

LET OP: vanwege afwijkingen in de productie kan de werkelijke afmeting na montage een klein beetje afwijken van de opgegeven afmetingen

NOTA: A causa di variazioni nella produzione, le dimensioni effettive del prodotto assemblato potrebbero variare leggermente da quelle indicate

NOTA: Devido a variações na produção o tamanho real da montagem poderá variar ligeiramente das dimensões especificadas.

SHED PARTS | PIÈCES DE L'ABRI | PARTES DEL COBERTIZO | TEILE DES SCHUPPENS | ONDERDELEN VAN HET SCHUURTJE
 | COMPONENTI DELLA CASETTA | PEÇAS DO ABRIGO

Remove all parts from the package(s) and spread them out on a clean work surface | Code letters are imprinted on each part for easy identification | Retirez toutes les pièces du/des paquet(s) et étalez-les sur une surface de travail propre | Des lettres sont imprimées sur chaque pièce pour une identification facile | Saque todas las piezas del paquete o paquetes y póngalas sobre una superficie de trabajo limpia | El código de letras está marcado en cada pieza para que sea más fácil identificarla | Nehmen Sie alle Teile aus der Verpackung und breiten Sie sie auf einer sauberen Arbeitsfläche aus | Auf jedem Teil sind Kennbuchstaben aufgedruckt, die die Zuordnung der einzelnen Teile erleichtern | Haal alle onderdelen uit het pakket (of uit de pakketten) en leg ze op een schoon werkoppervlak | Op ieder onderdeel zijn codes aangebracht voor een gemakkelijke identificatie | Rimuovere tutti i componenti dall'imballo e posizionarli su una superficie di lavoro pulita | I codici identificativi sono impressi in ogni componente per una semplice identificazione | Retire todas as peças da embalagem e espalhe-as numa superfície de trabalho limpa | Existem letras de código impressas em cada peça para fácil identificação

FLOOR PARTS | ÉLÉMENTS DU PLANCHER | PARTES DEL SUELO | BODENTEILE | VLOERPANELEN | COMPONENTI DEL PAVIMENTO | PEÇAS DO CHÃO

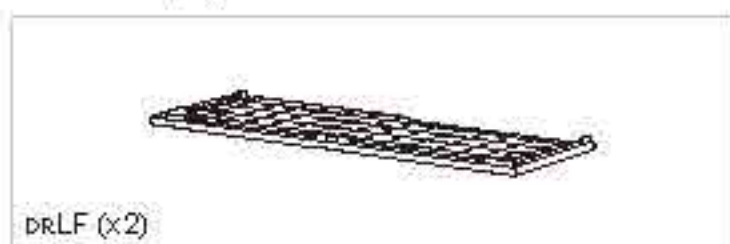

WALL PARTS | PIÈCES DES MURS | PARTES DE LAS PAREDES | WANDELEMENTE | MUURONDERDELEN | COMPONENTI DELLA PARETE | PAINÉIS LATERAIS

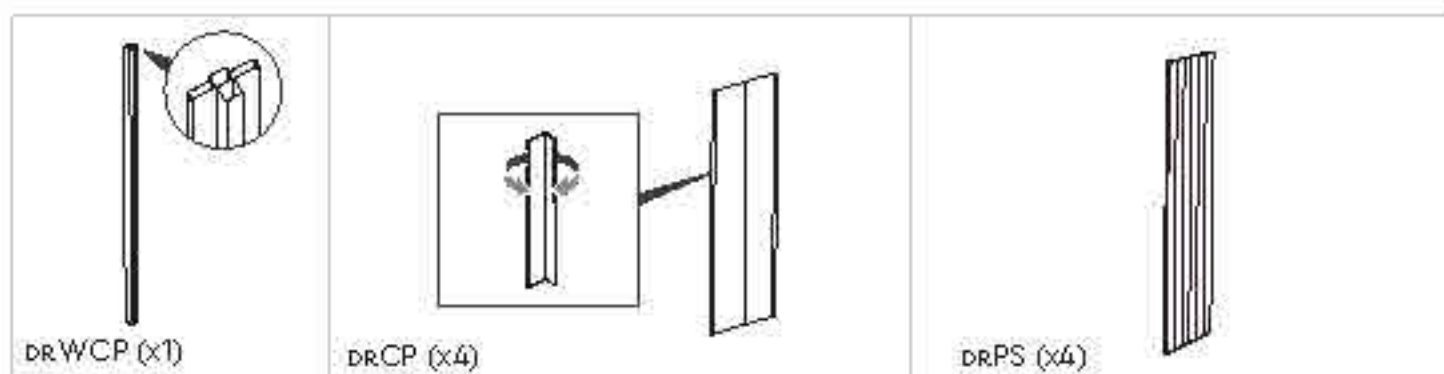



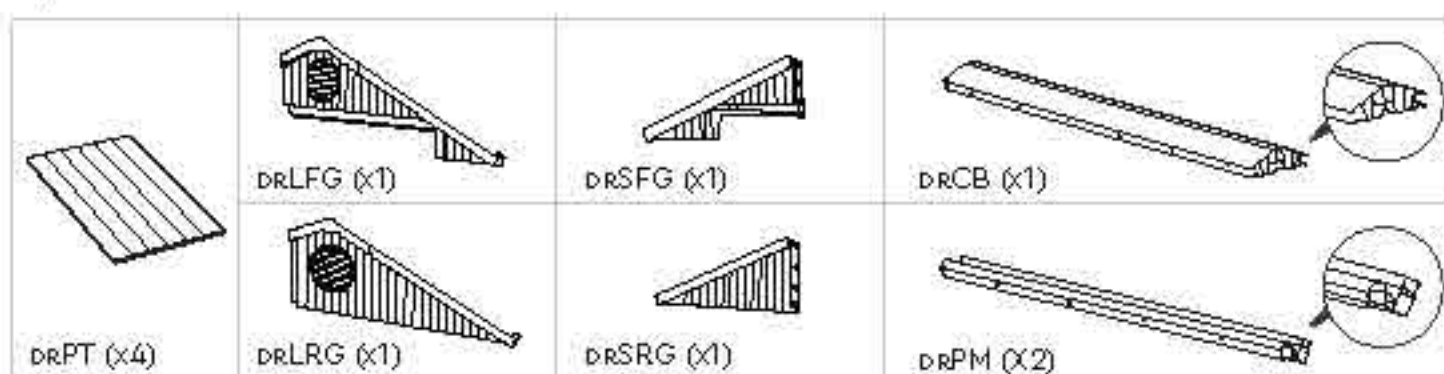





ROOF PARTS | PIÈCES DU TOIT | DACHELEMENTE | PARTES DEL TECHO | DAKONDERDELEN | COMPONENTI DEL TETTO | PEÇAS DO TELHADO

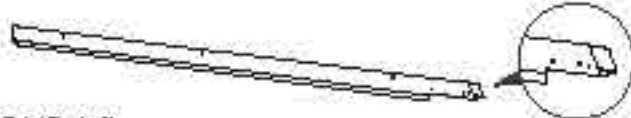

DOOR PARTS | PIÈCES DE LA PORTE | TÜRELEMENTE | PARTES DE LA PUERTA | DEURONDERDELEN | COMPONENTI DELLA PORTA | PEÇAS DAS PORTAS

| | |
|--|--|
|  <p>DR6D (x2)</p> |  <p>DRPD (x4)</p> |
|--|--|

METAL PARTS | PIÈCES MÉTALLIQUES | PIEZAS METÁLICAS | METALLTEILE | METALEN DELEN | COMPONENTI IN METALLO | PARTES METÁLICAS

| | |
|---|--|
|  <p>DRDML (x1)</p> |  <p>DRMDT (x2)</p> |
|  <p>DRDMR (x1)</p> |  <p>DRMA (x3)</p> |
|  <p>DRMTF (x1)</p> |  <p>DRMW (x1)</p> |
|  <p>DRWMP (x1)</p> |  <p>D6BP (x1)</p> |

SMALL PARTS | PETITES PIÈCES | PARTES PEQUEÑAS | KLEINTEILE | KLEINE ONDERDELEN | MINUTERIA | PEÇAS PEQUENAS

| | | | | |
|--|--|--|---|--|
|  <p>DRHG (x4)</p> |  <p>DRLM (x1)</p> |  <p>DRLH (x1)</p> |  <p>D6L (x2)</p> |  <p>DRCC (x4)</p> |
|--|--|--|---|--|

SCREWS | VIS | SCHRAUBEN | TORNILLOS | SCHROEYEN | VITI | PARAFUSOS | ŠRUBY

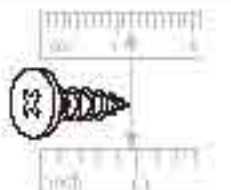
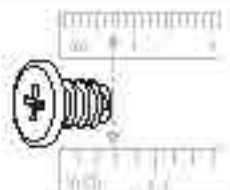
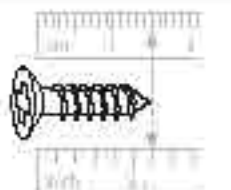
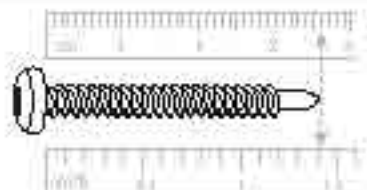
| | | | |
|--|--|--|---|
|  <p>sc12t (x14) 12 mm / 0.47"</p> |  <p>sc7t (x12) 7 mm / 0.28"</p> |  <p>sw15d (x29) 15 mm / 0.6"</p> |  <p>sc35 (x18) 35 mm / 1.42"</p> |
|--|--|--|---|

1



drLF (x2)

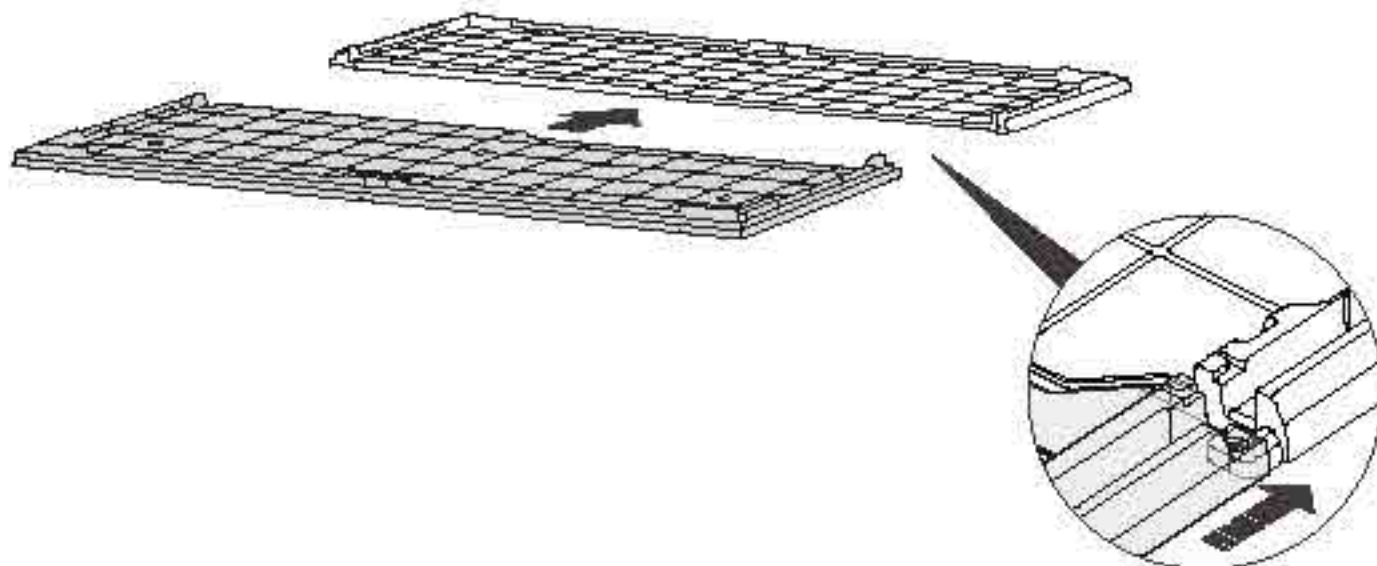

2



sc12t (x8)

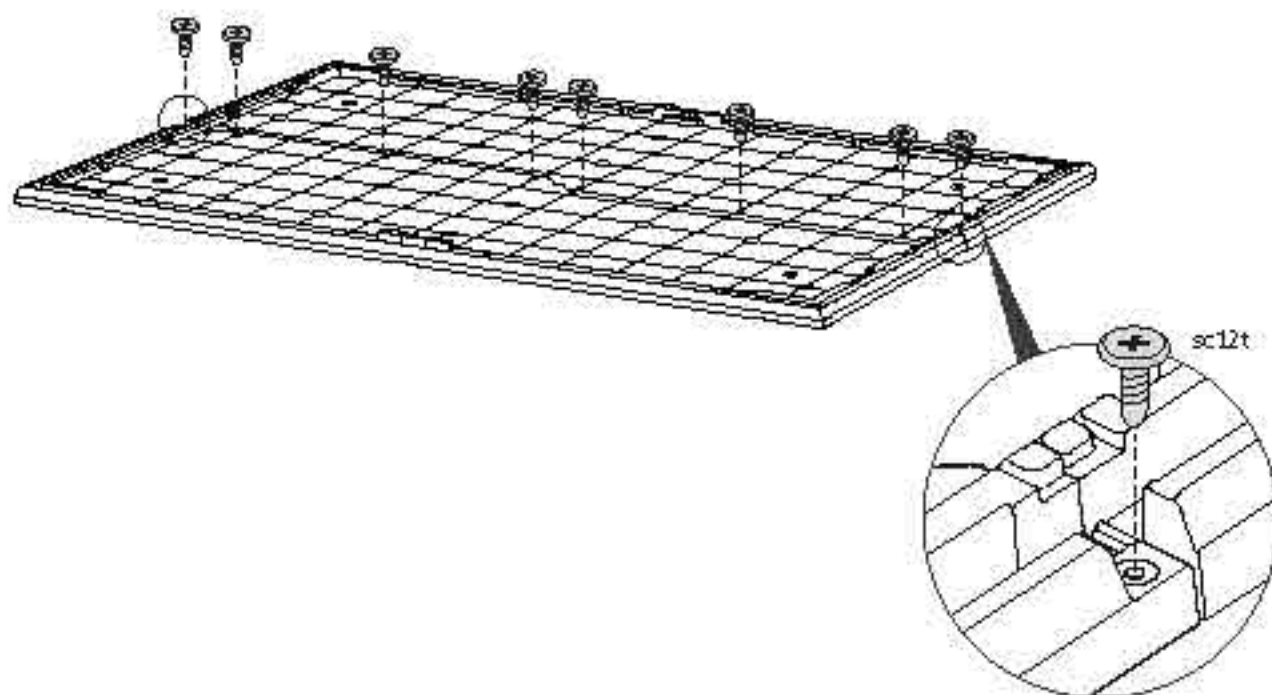

3 | DRCP (x1) | 

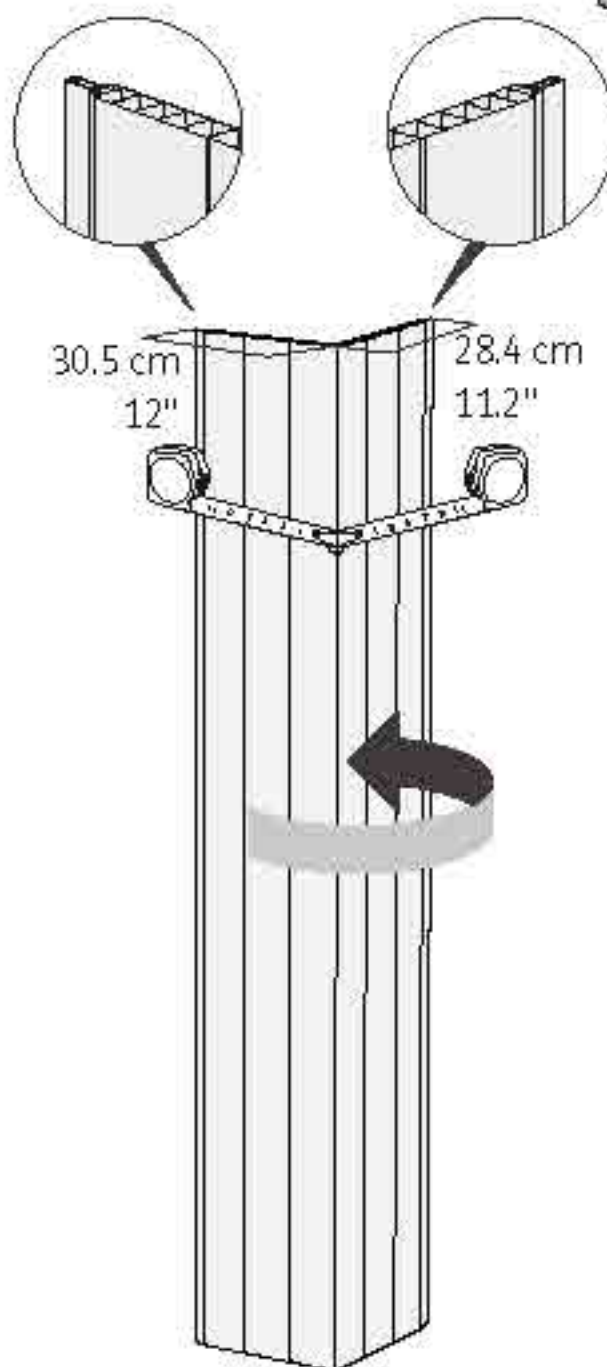

Asymmetric
 Asymétrique
 Asimétrico
 Asymmetrisch
 Asymmetrisch
 Asimmetrico
 Assimétrico

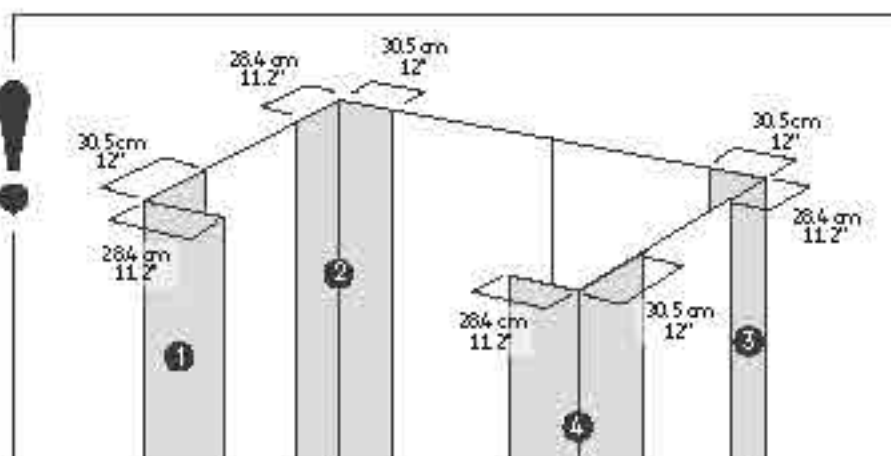

4

DRCP (x1)

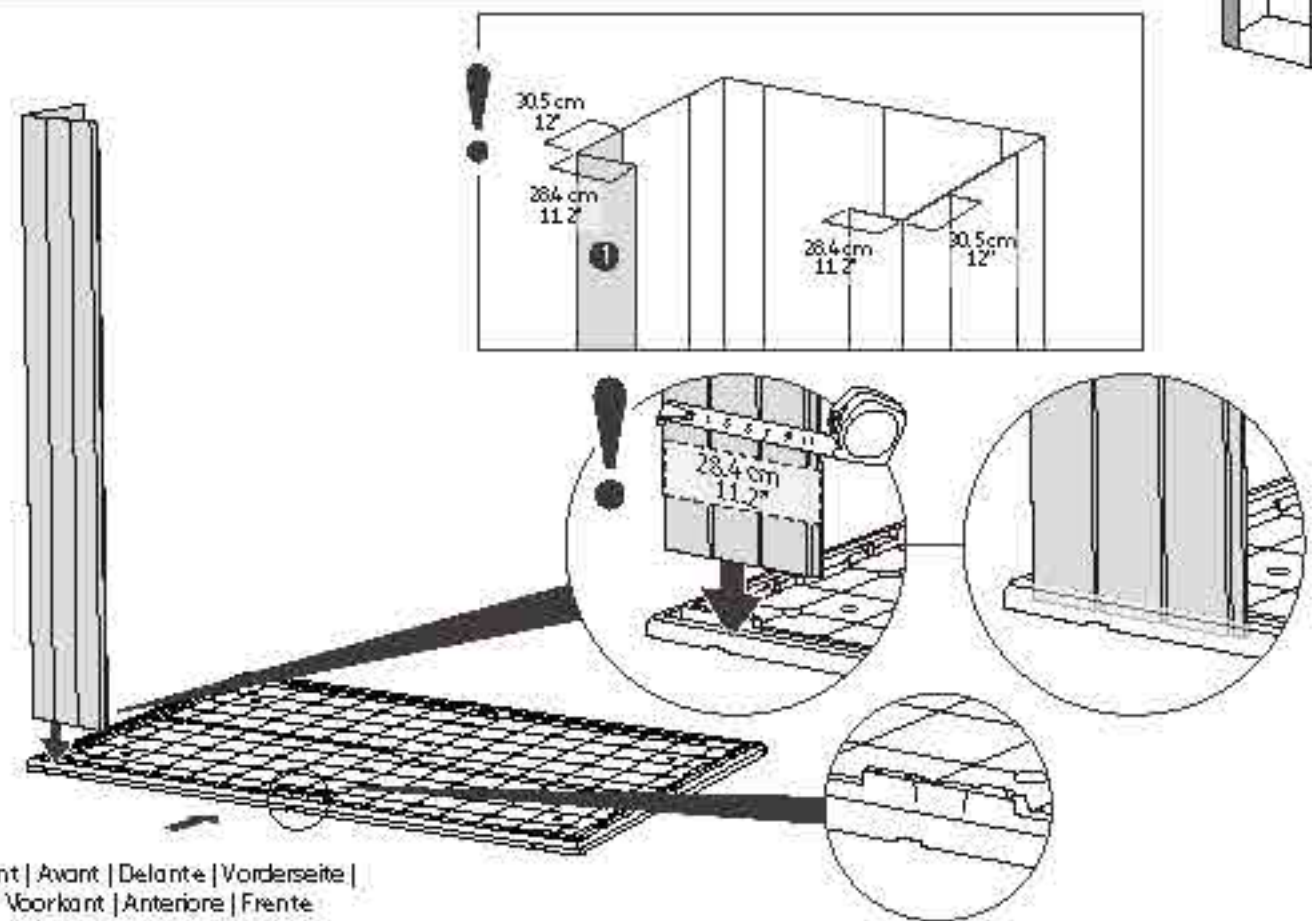

5

DRPS (x1)

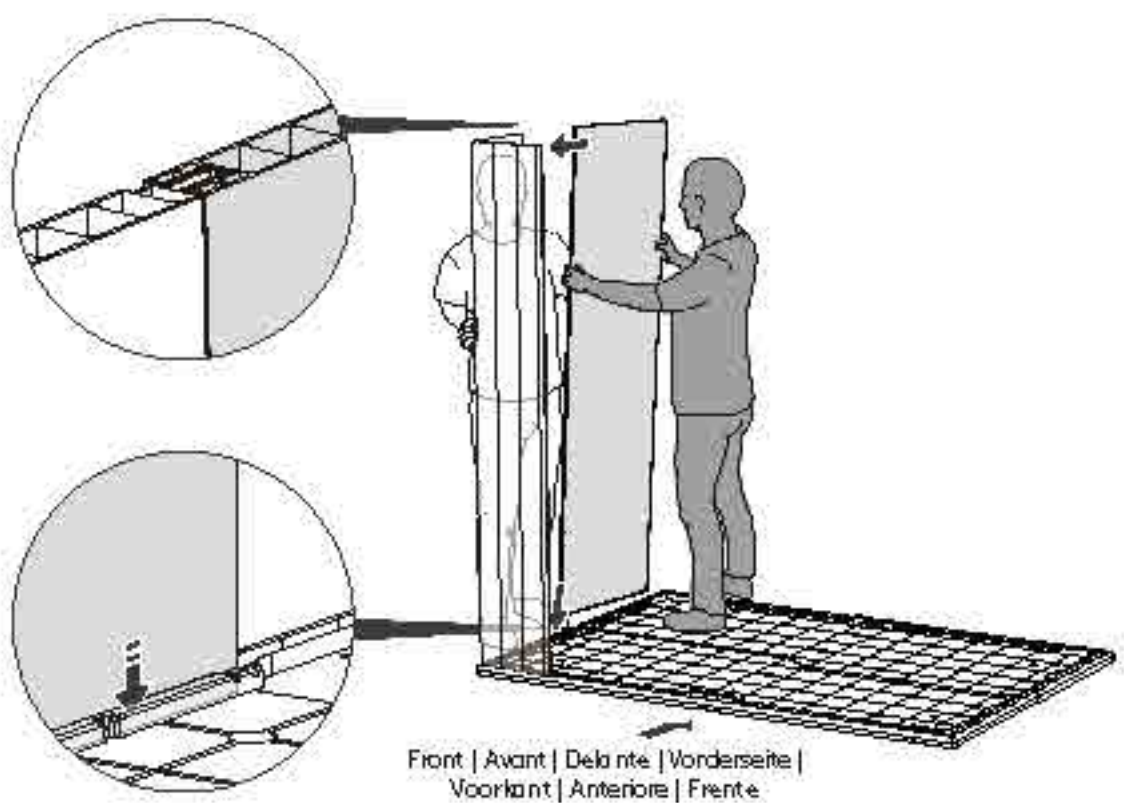
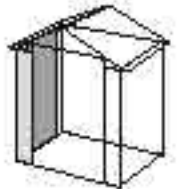

6

sc12t (x1)

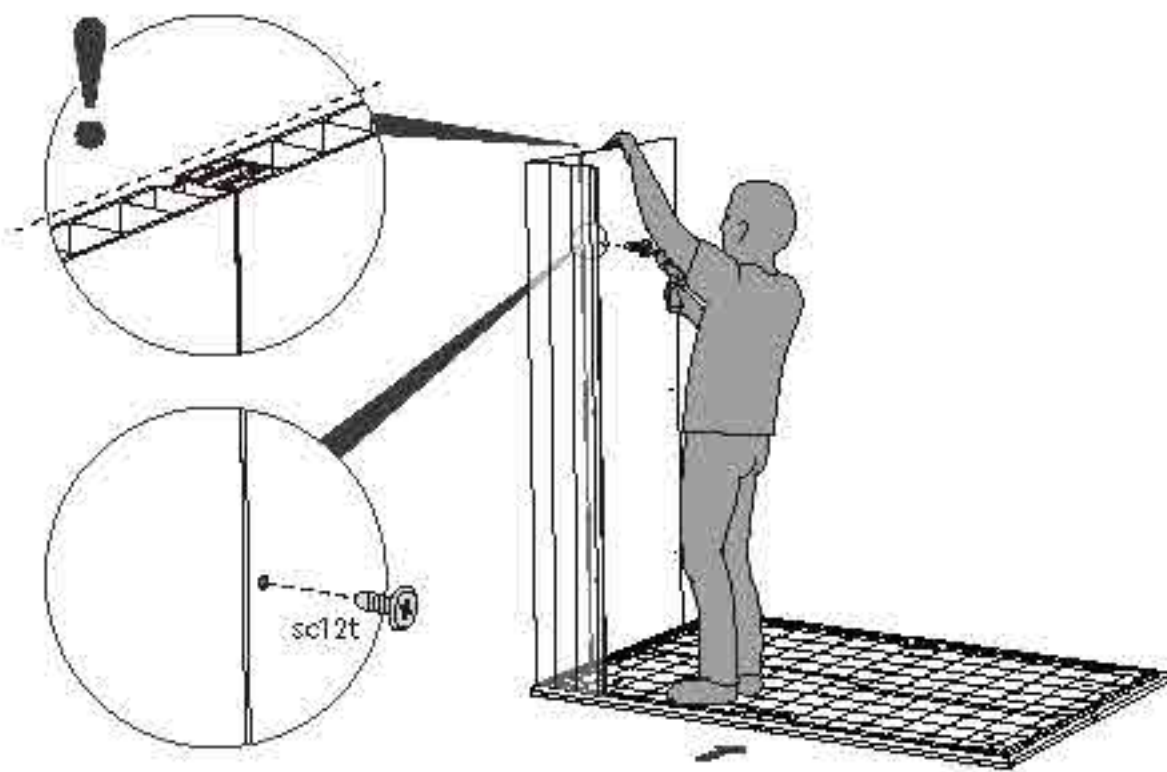
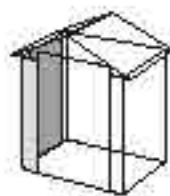

Front | Avant | Delante | Vorderseite |
Voorlant | Anteriore | Frente

7

DRCP (x1)

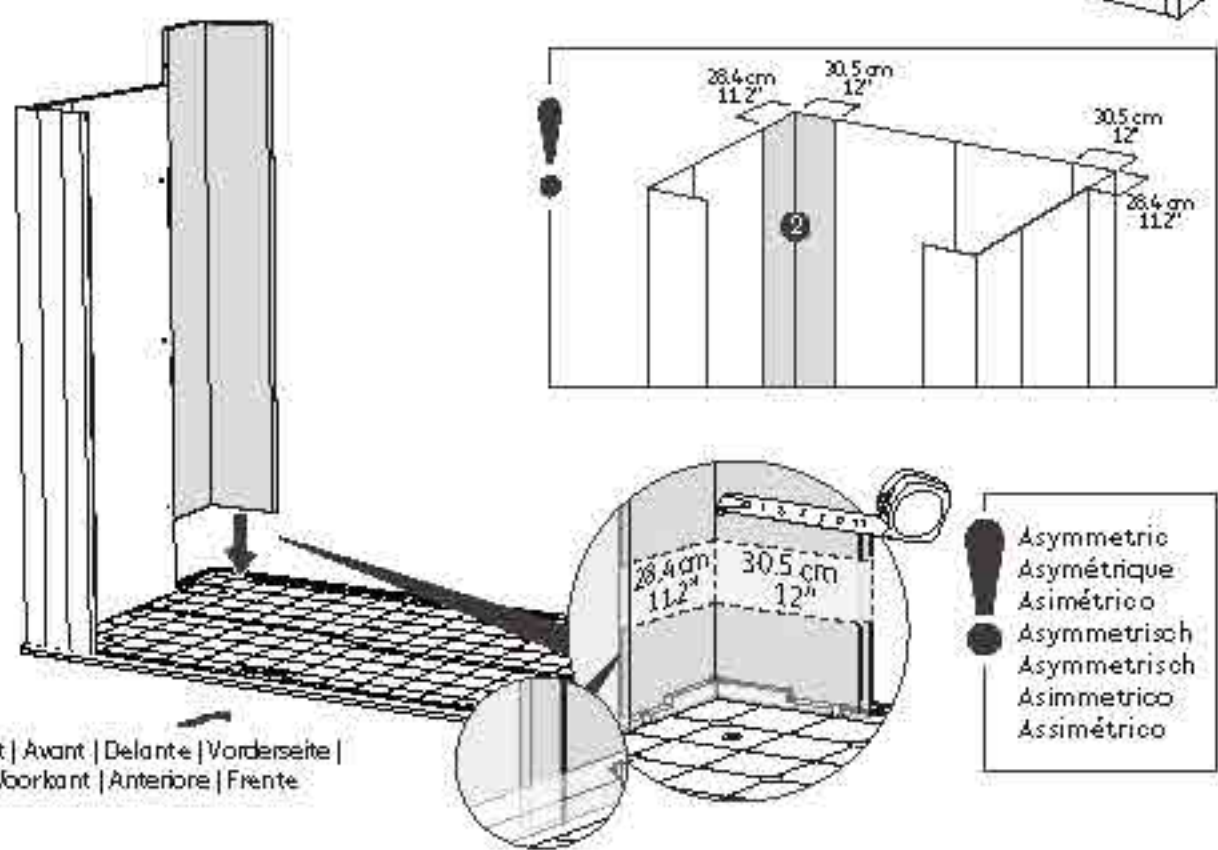
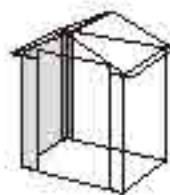

Front | Avant | Delante | Vorderseite |
Voorlant | Anteriore | Frente

8

sc12t (x1)

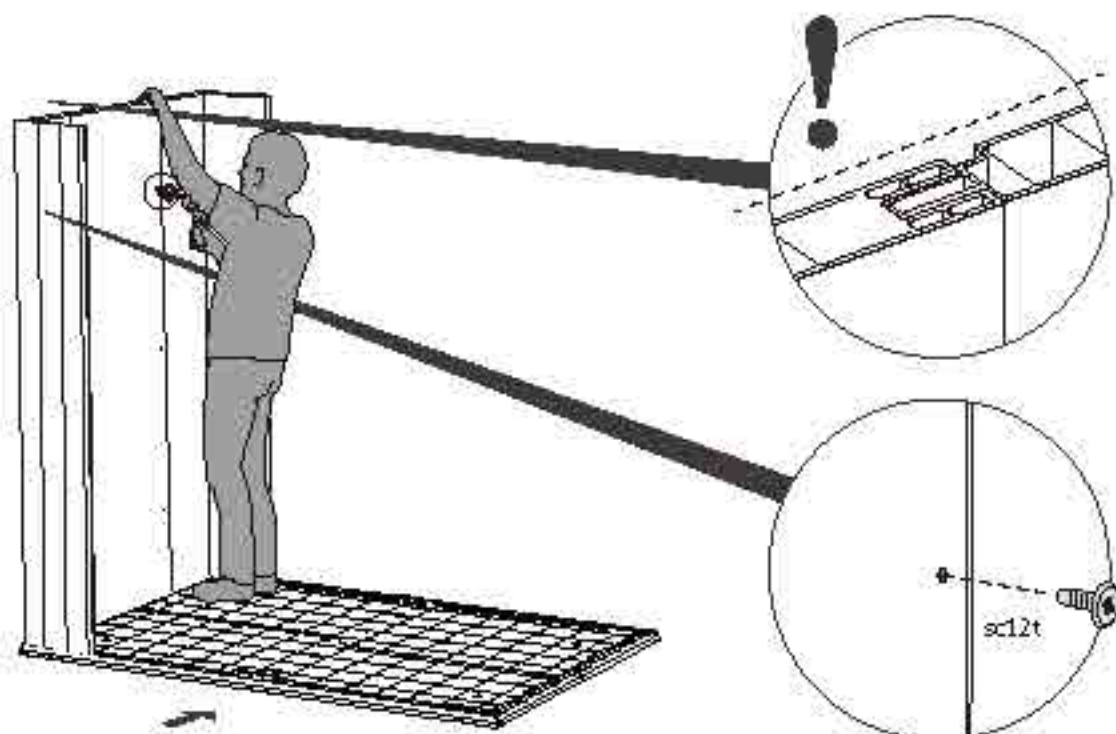

Front | Avant | Delante | Vorderseite |
Voorkant | Anteriore | Frente

9

DRPS (x1)

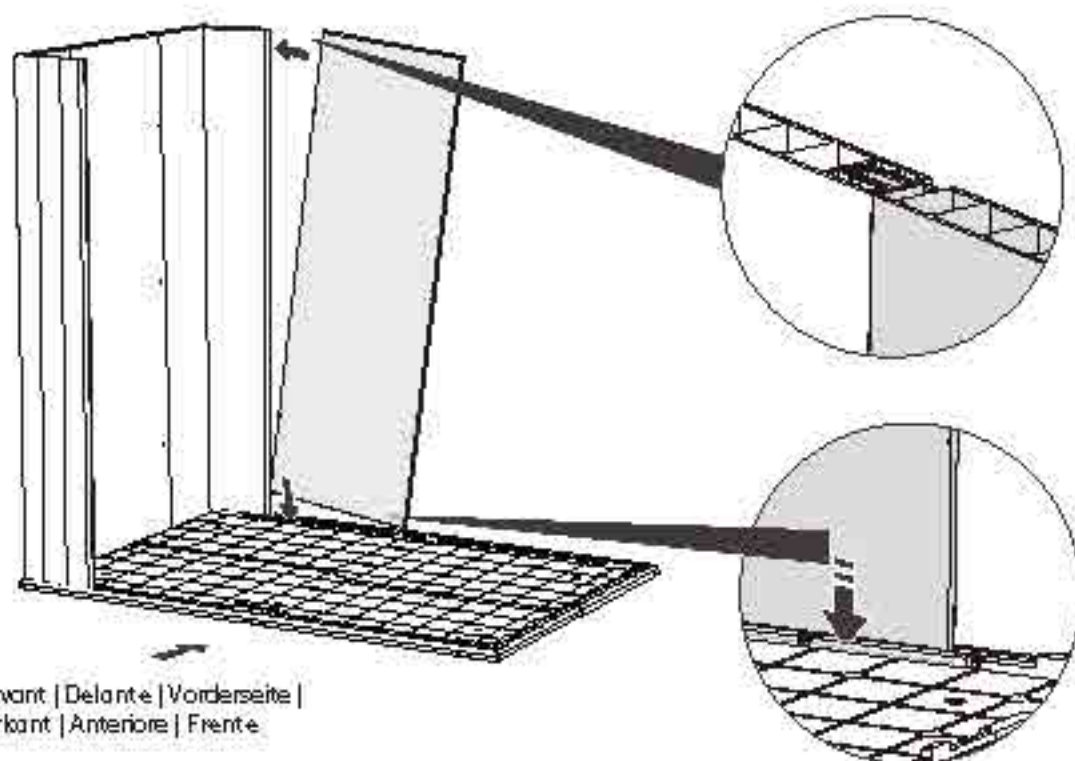
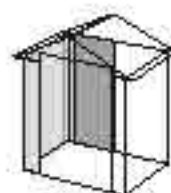

Front | Avant | Delante | Vorderseite |
Voorkant | Anteriore | Frente

10

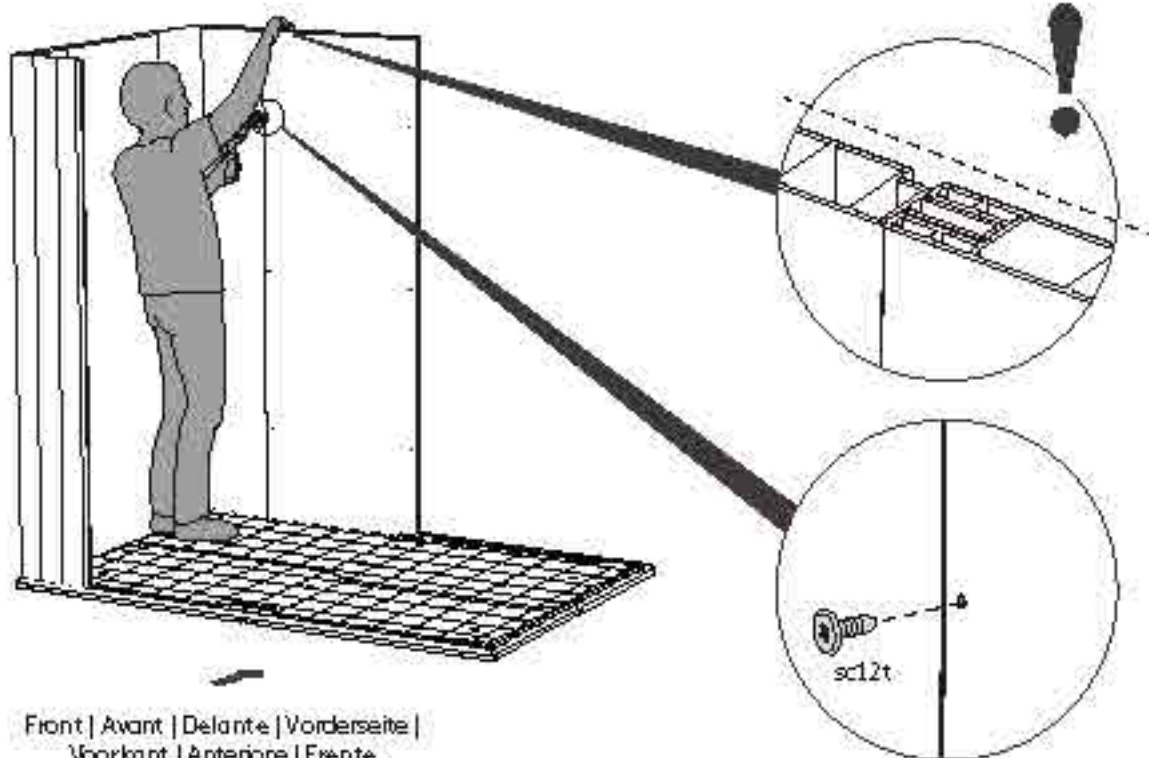
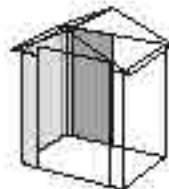
 sc12t (x1)

Front | Avant | Delante | Vorderseite |
Voorkant | Anteriore | Frente

11

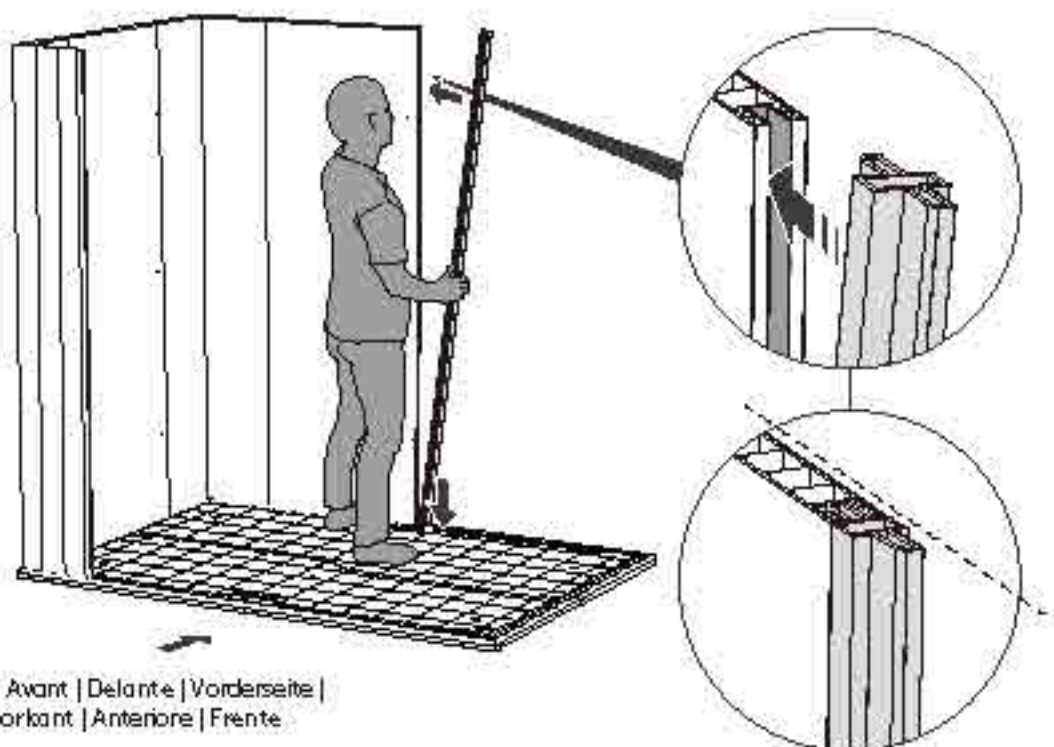
 DRWCP (x1)

Front | Avant | Delante | Vorderseite |
Voorkant | Anteriore | Frente

12



sc12t (x1)

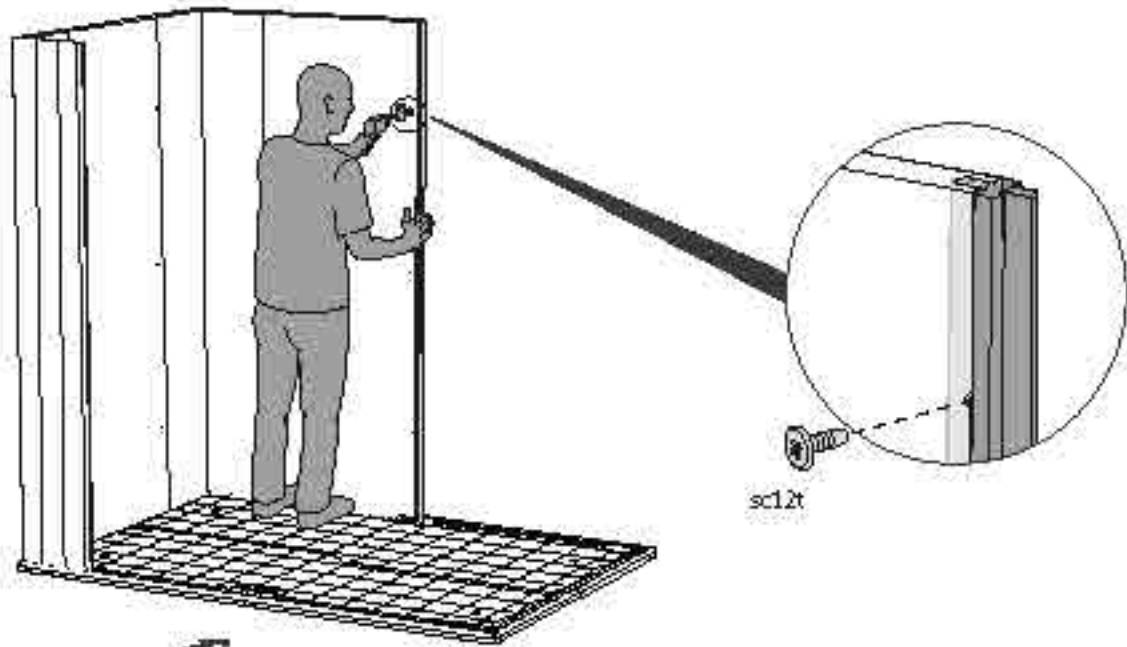

Front | Avant | Delante | Vorderseite |
 Voorkant | Anteriore | Frente

13

DRPS (x1)

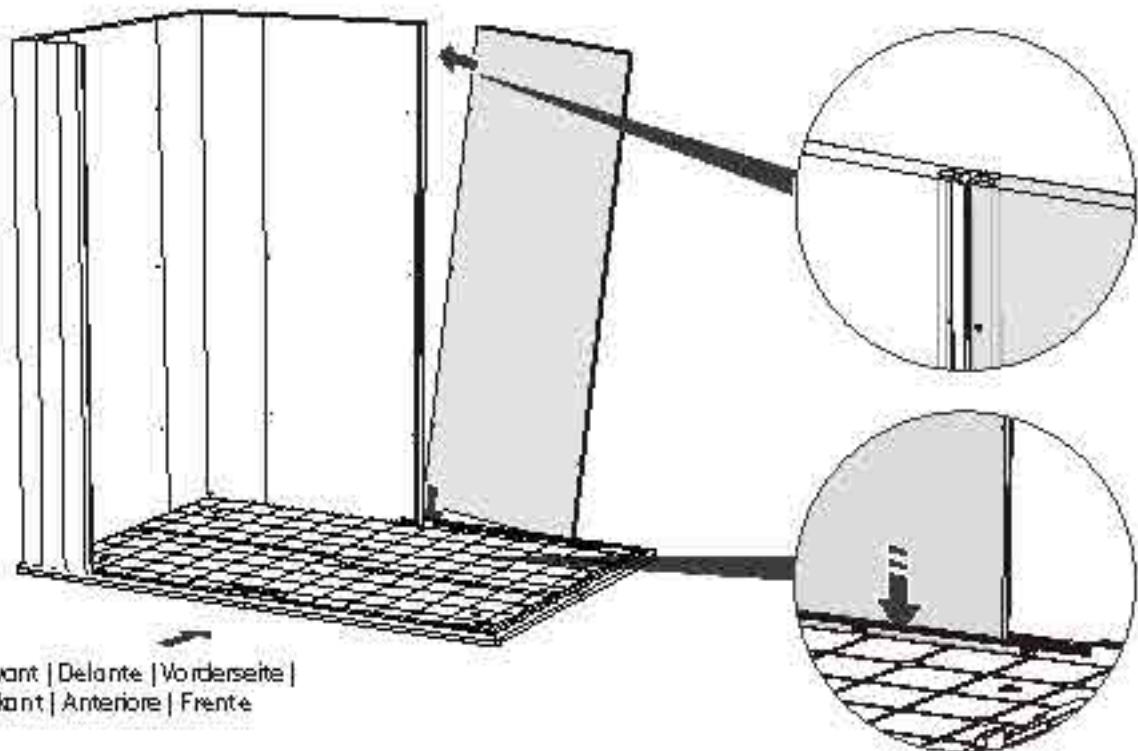
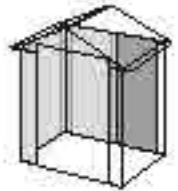

Front | Avant | Delante | Vorderseite |
 Voorkant | Anteriore | Frente

14

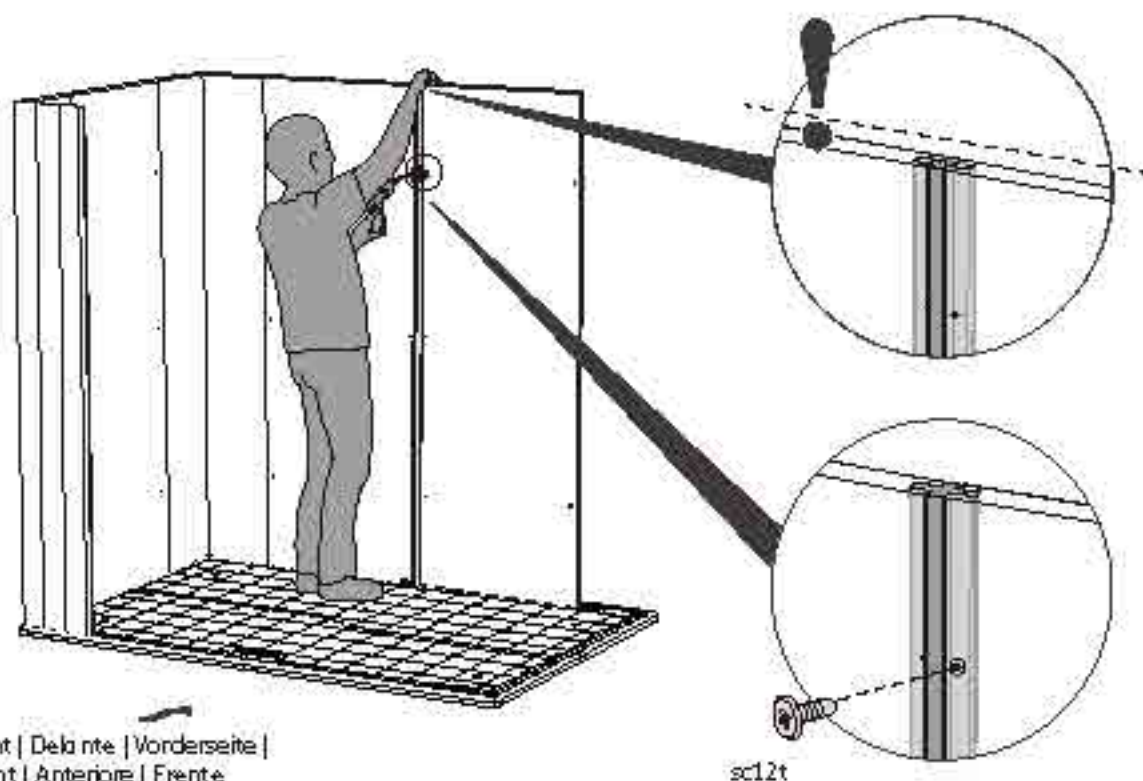
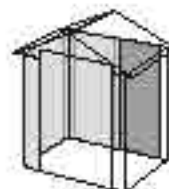
 sc12t (x1)

Front | Avant | Dela nte | Vorderseite |
Voorkant | Anteriore | Frente

sc12t

15

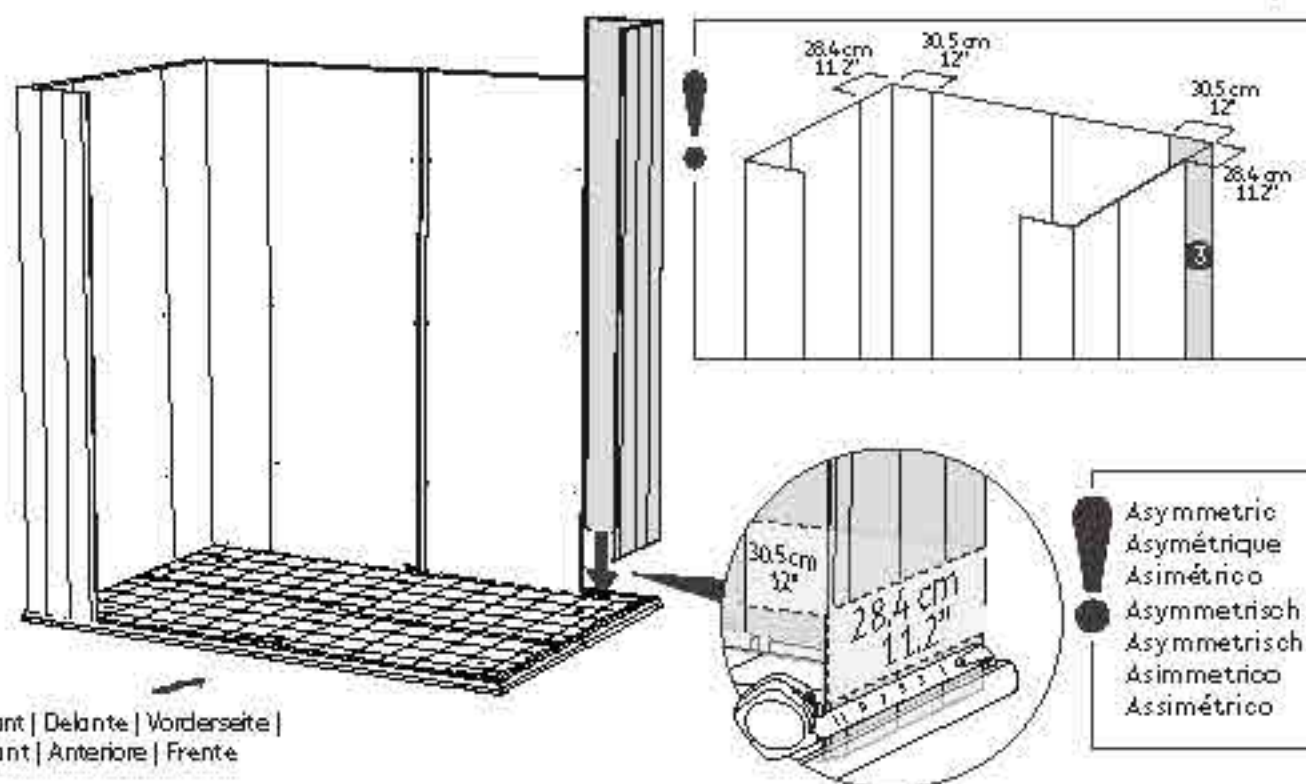
 DRCP (x1)

Front | Avant | Dela nte | Vorderseite |
Voorkant | Anteriore | Frente

Asymmetric
Asymétrique
Asimétrico
Asymmetrisch
Asimmetrisch
Assimétrico

16



sc12t (x1)

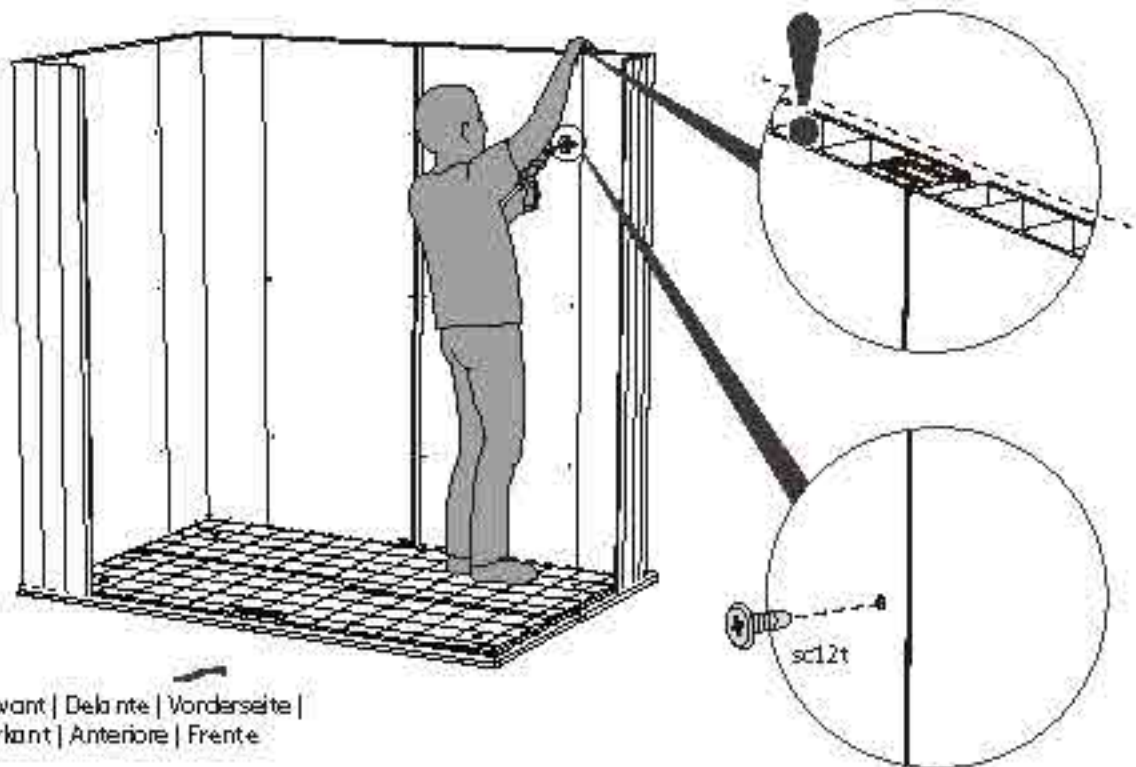

Front | Avant | Delante | Vorderseite |
 Voorkant | Anteriore | Frente

17

DRPS (x1)

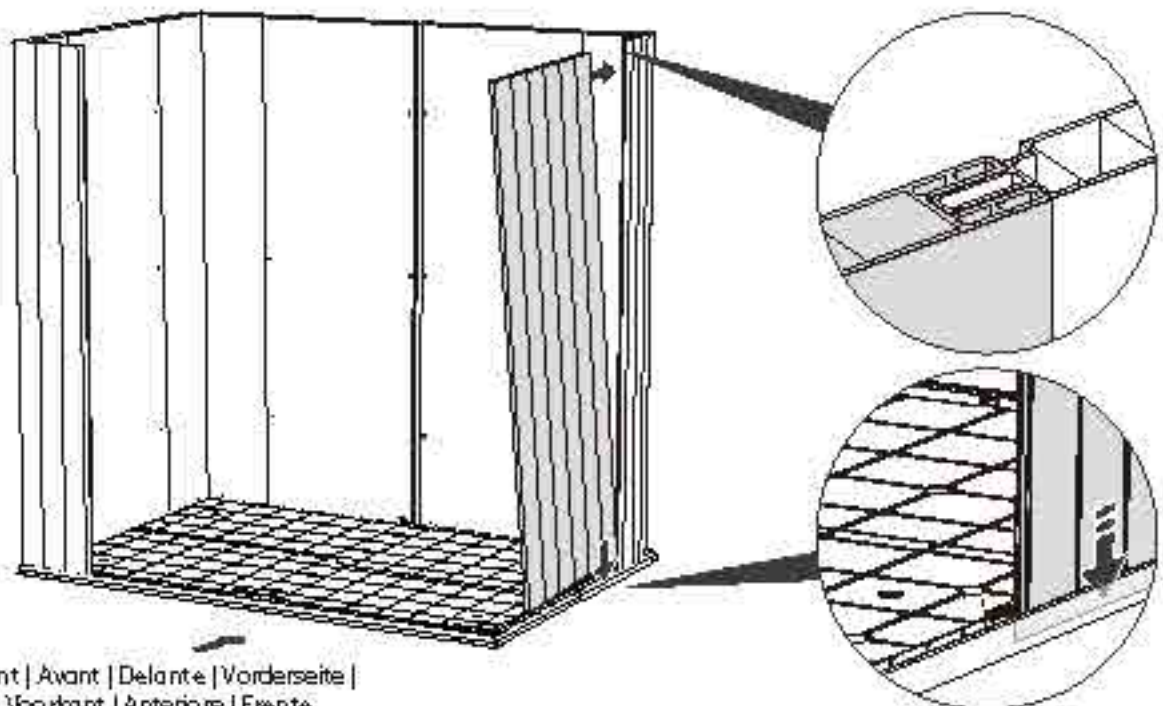

Front | Avant | Delante | Vorderseite |
 Voorkant | Anteriore | Frente

18



sc12t (x1)

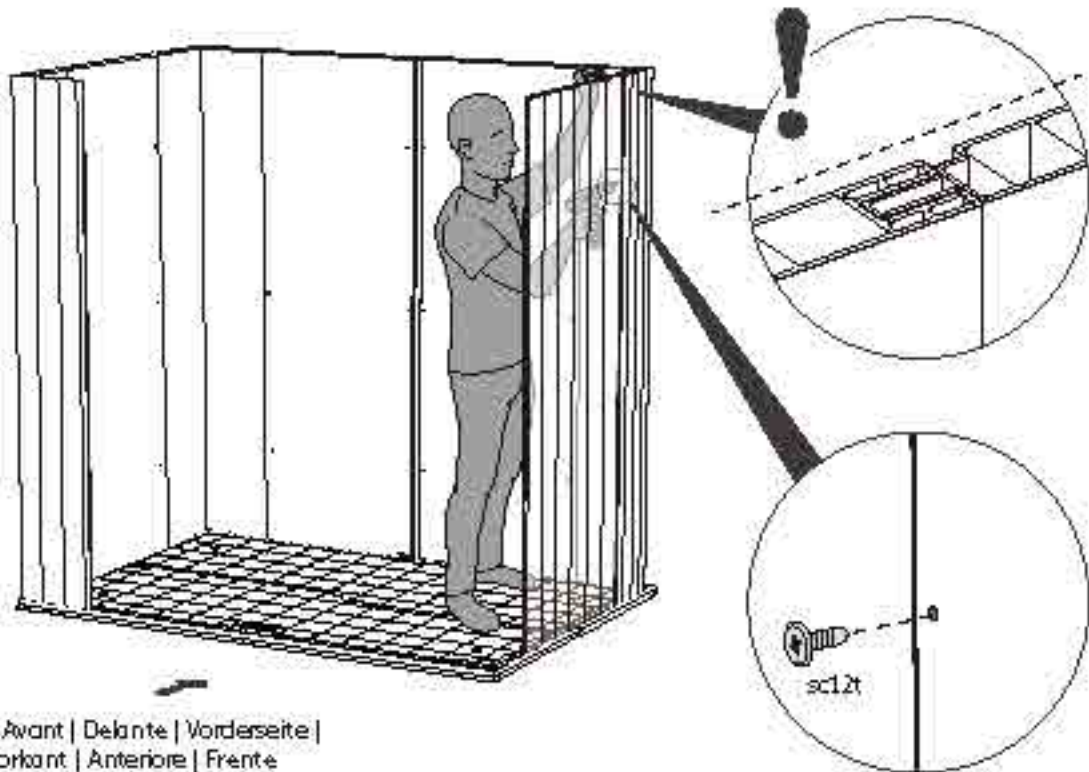

Front | Avant | Delante | Vorderseite |
Voorkant | Anteriore | Frente

19

DRCP (x1)

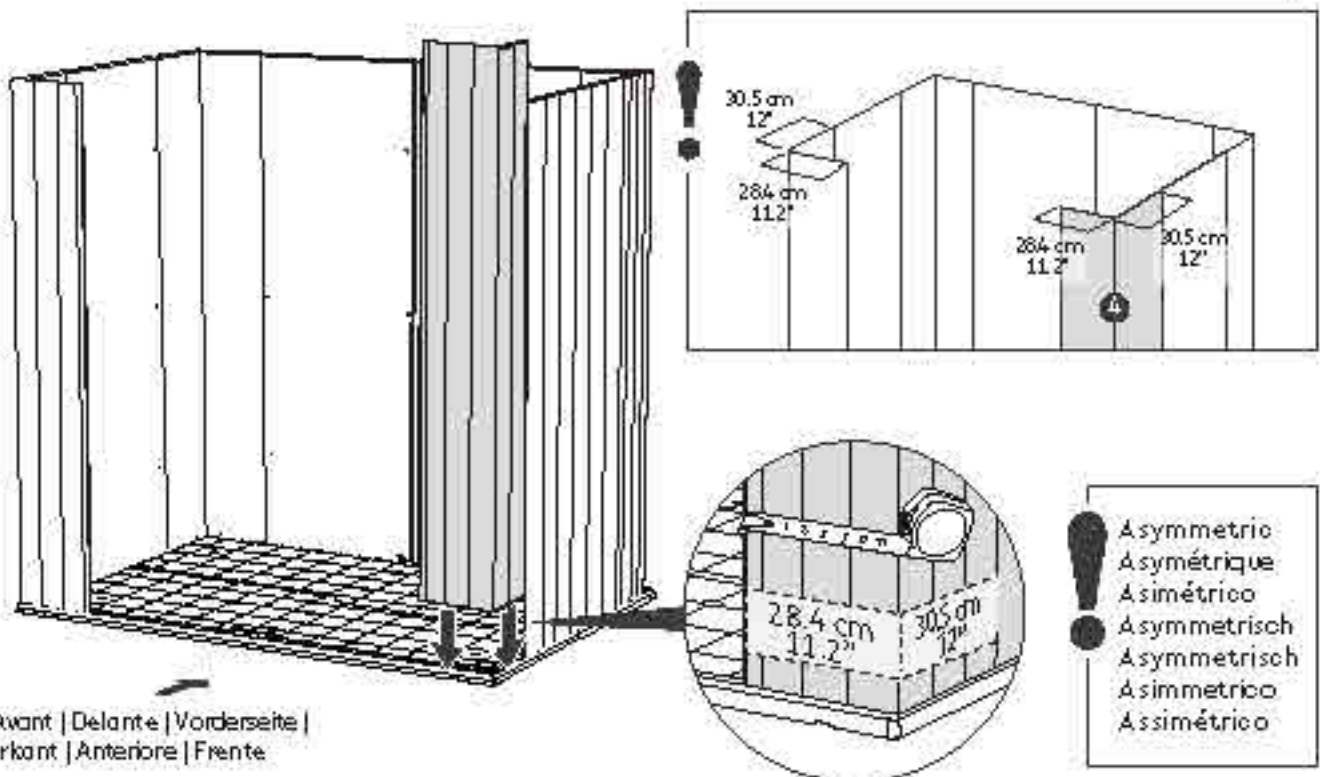

Front | Avant | Delante | Vorderseite |
Voorkant | Anteriore | Frente

Asymmetric
Asymétrique
Asimétrico
Asymmetrisch
Asimmetrisch
Asimétrico
Assimétrico

20

3  sc12t (x1)

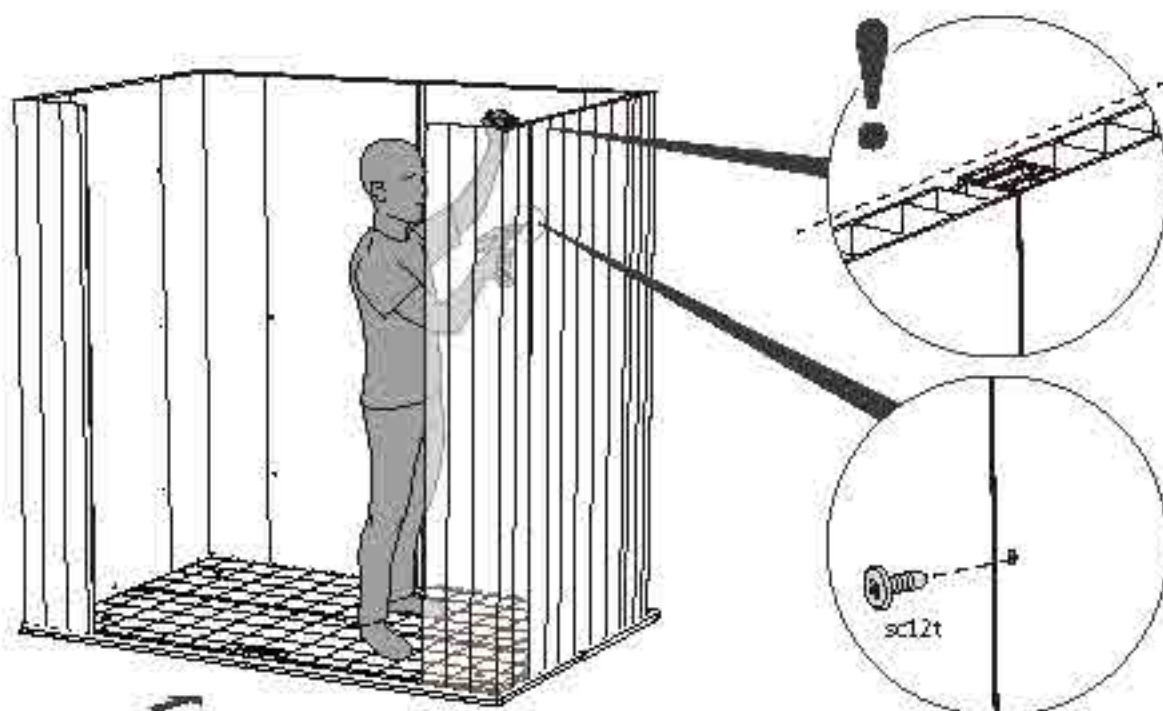

Front | Avant | Delante | Vorderseite |
Voorkant | Anteriore | Frente

21



DR LFG (x1)



DR SFG (x1)



SC12T (x3)

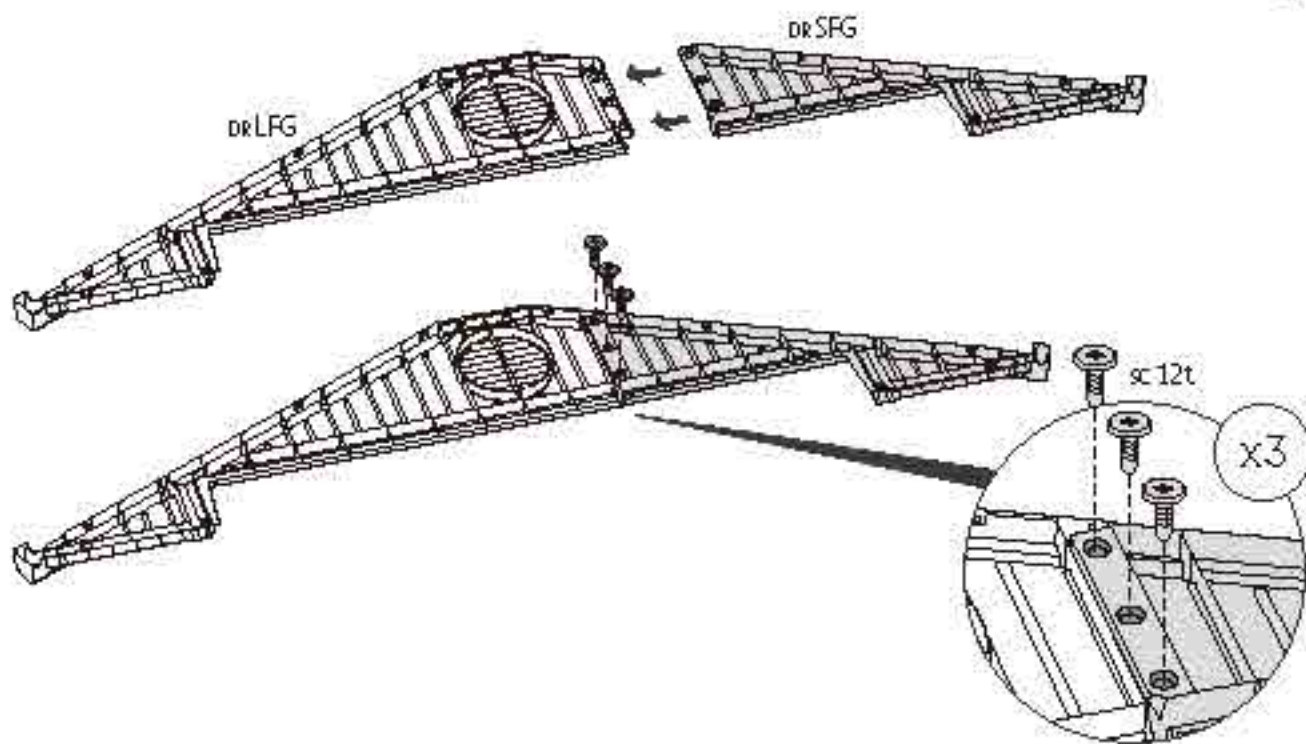
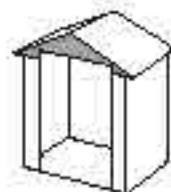

22



DR MTF (x1)



SC12T (x5)

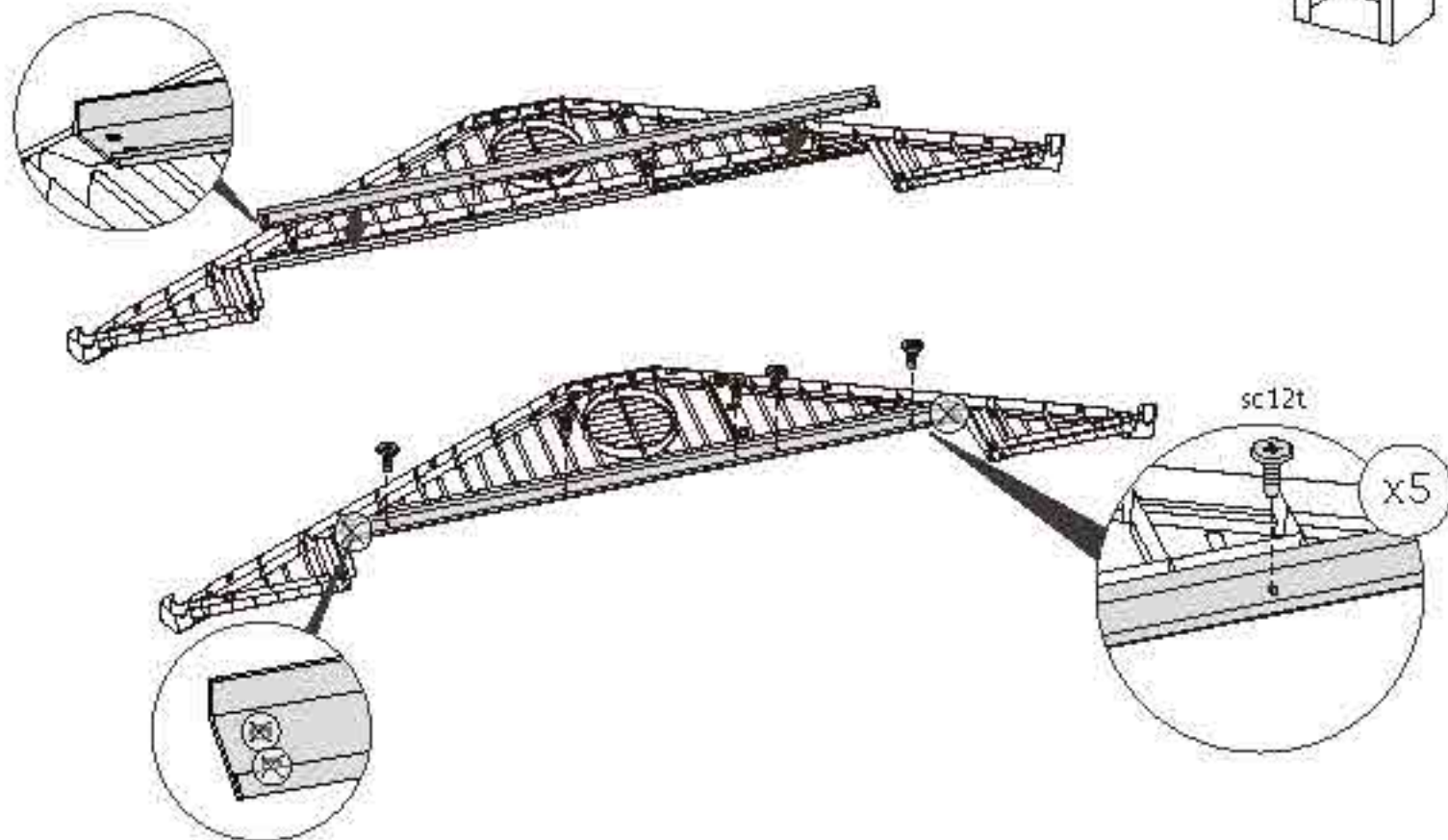

23



DRDML (x1)



DRDMR (x1)

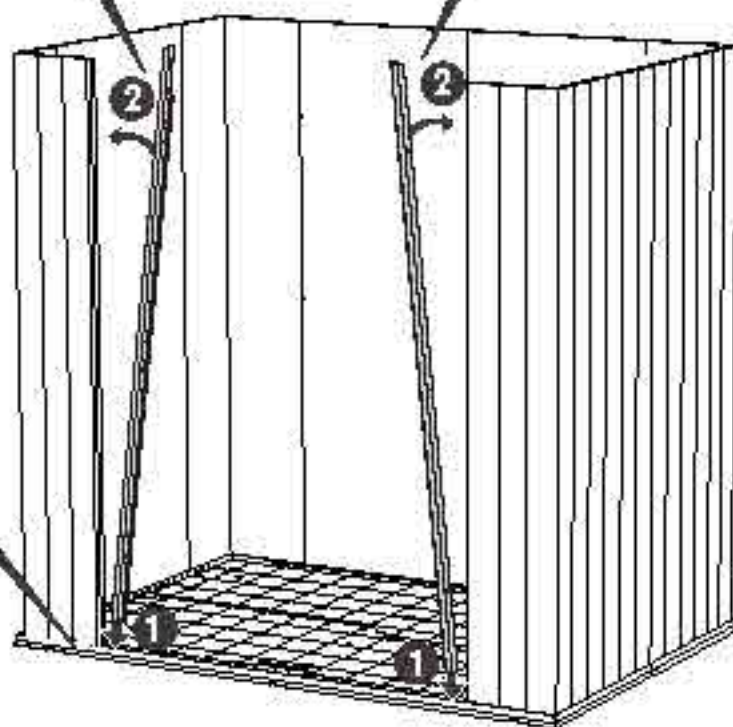
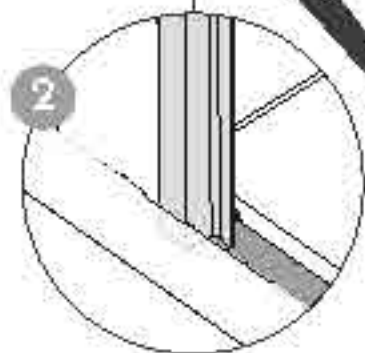
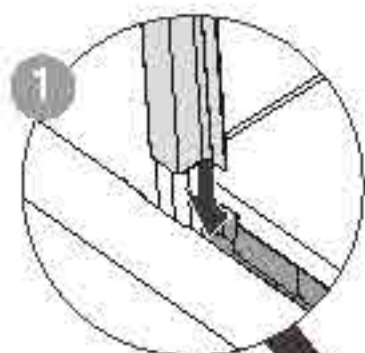
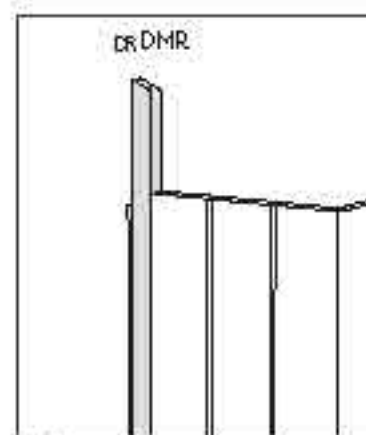
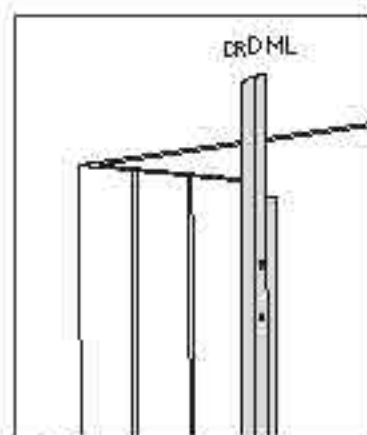

24

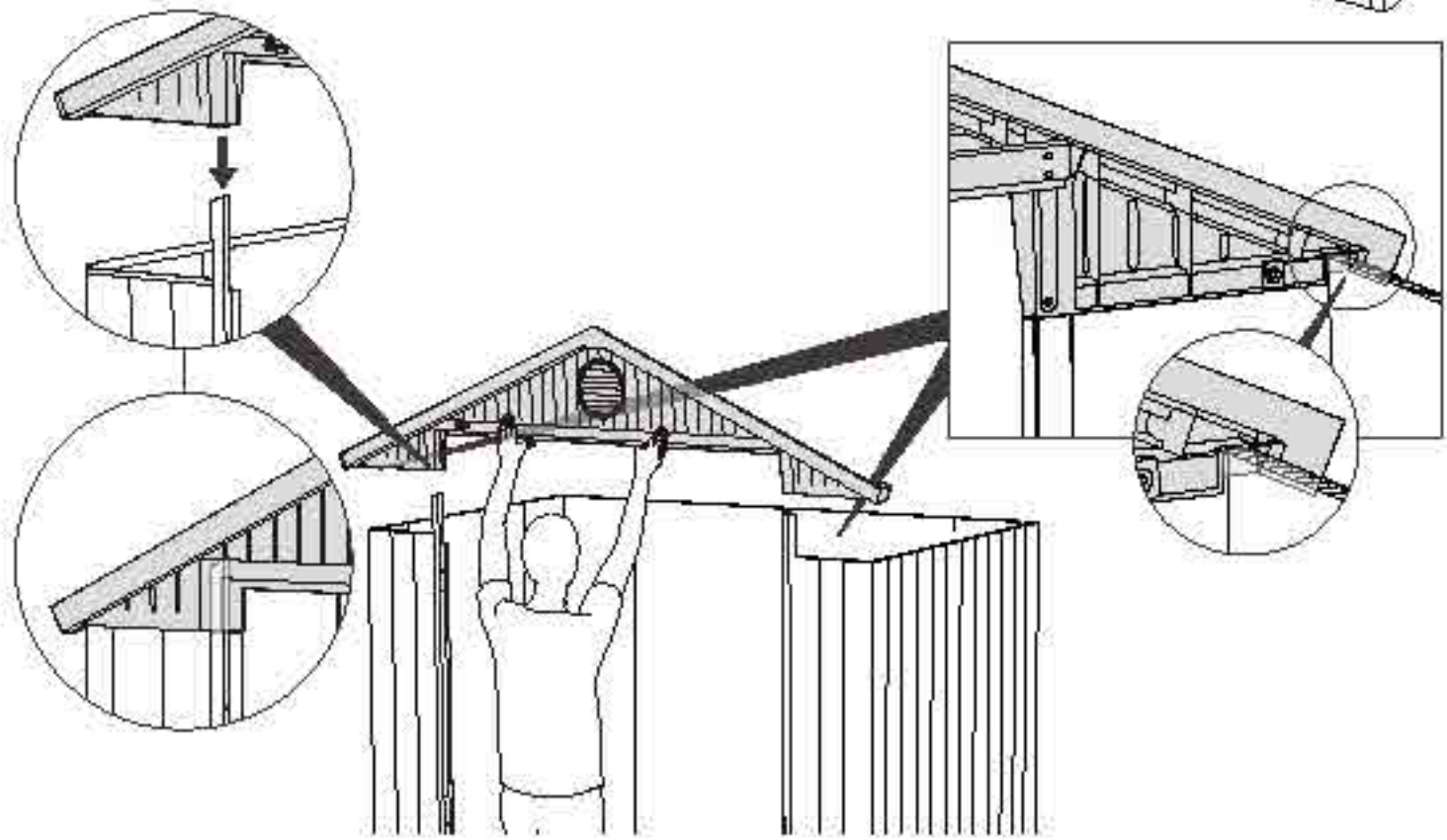

25

 sc12t (x4)

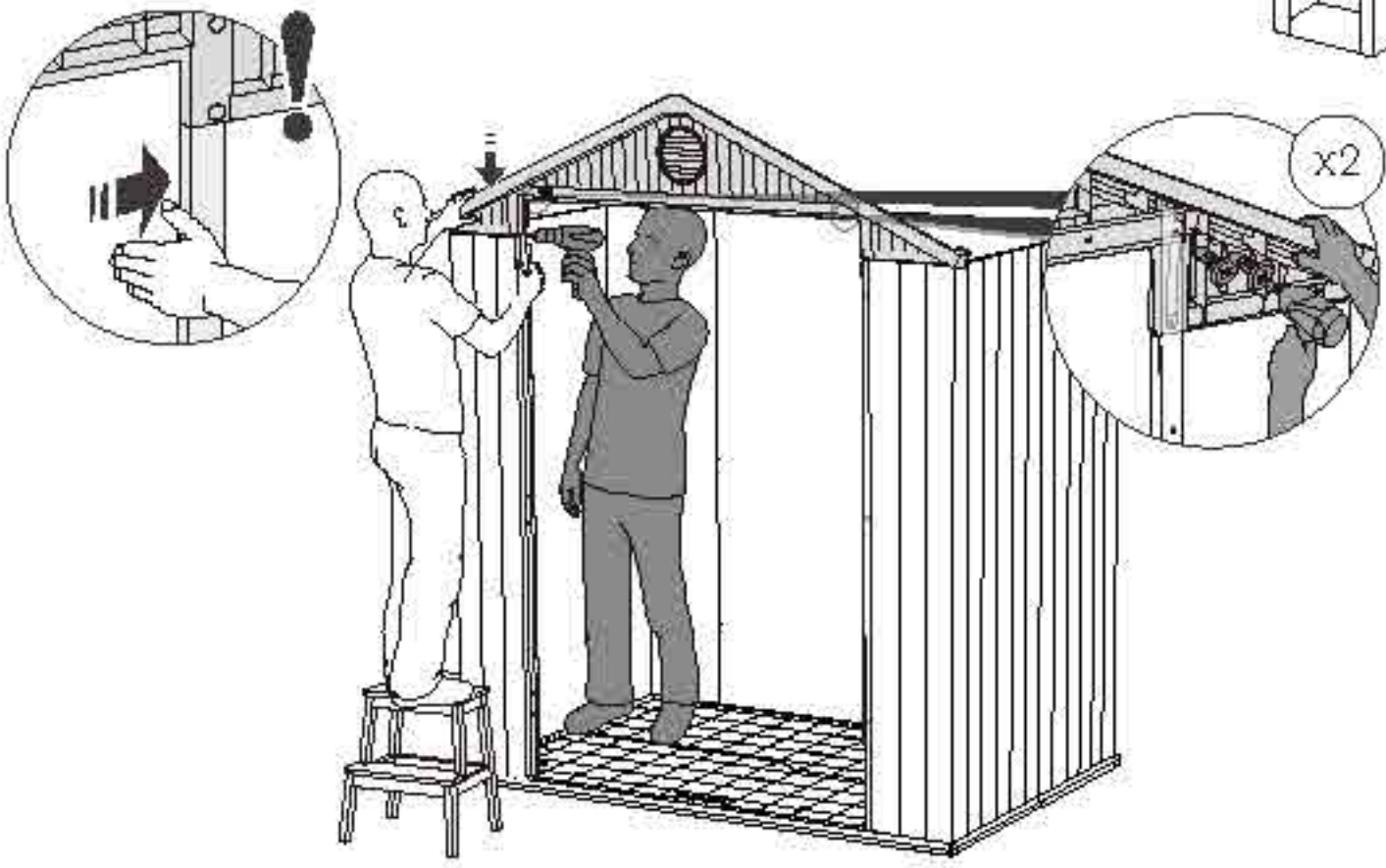

26

sc12t (x10)

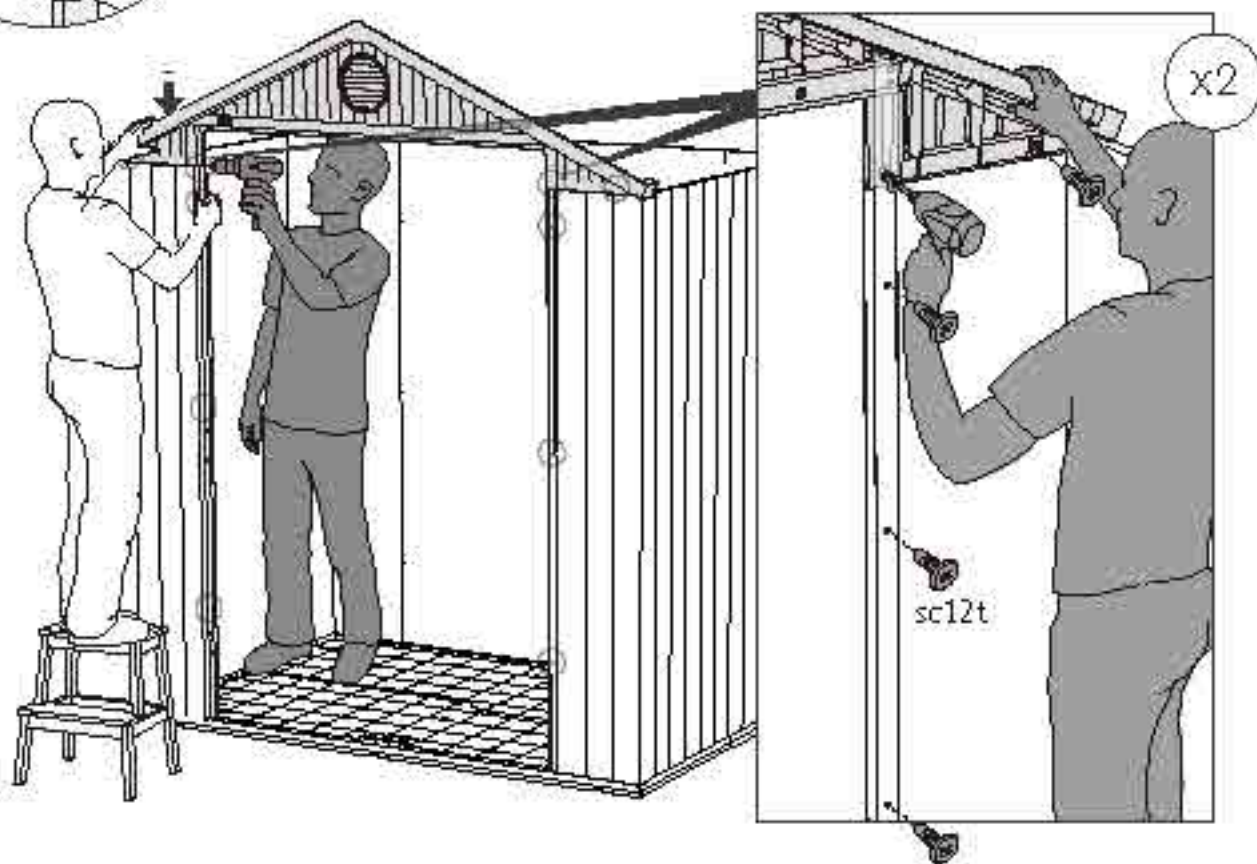
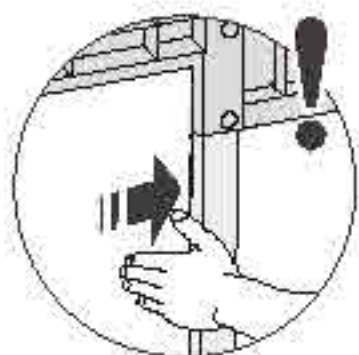

27



DRLRG (x1)



DRSRG (x1)



sc12t (x4)

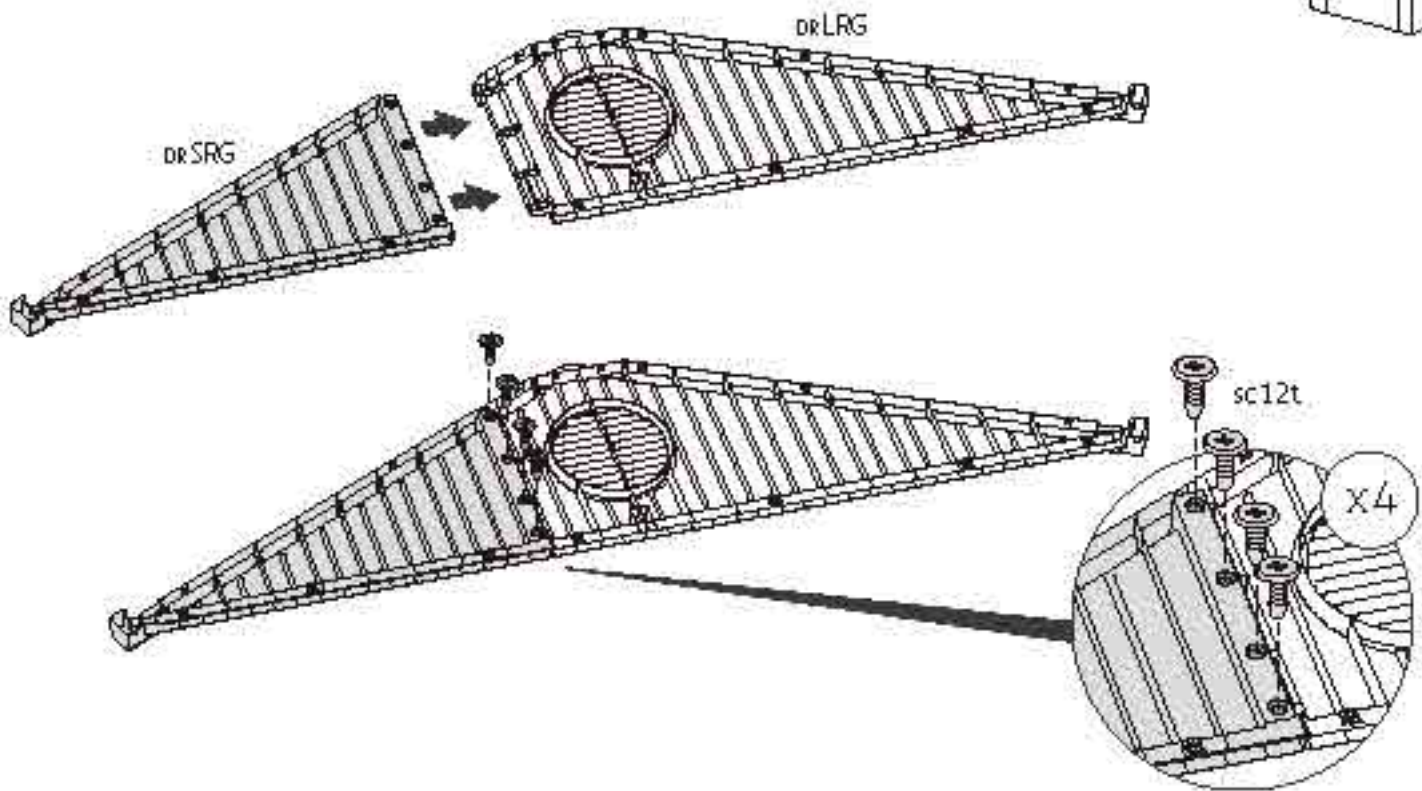
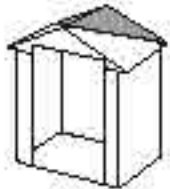

28

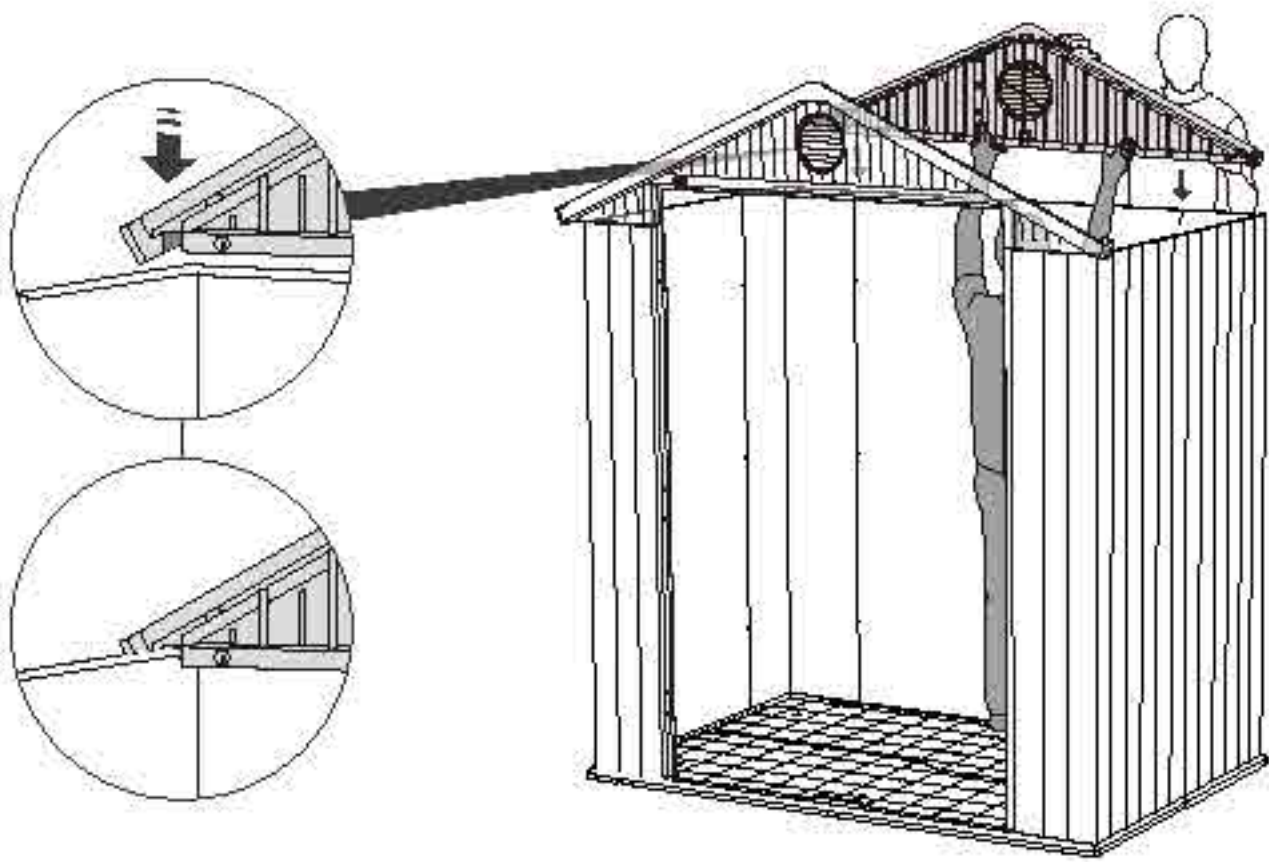
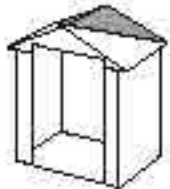

29



sc12t (x7)

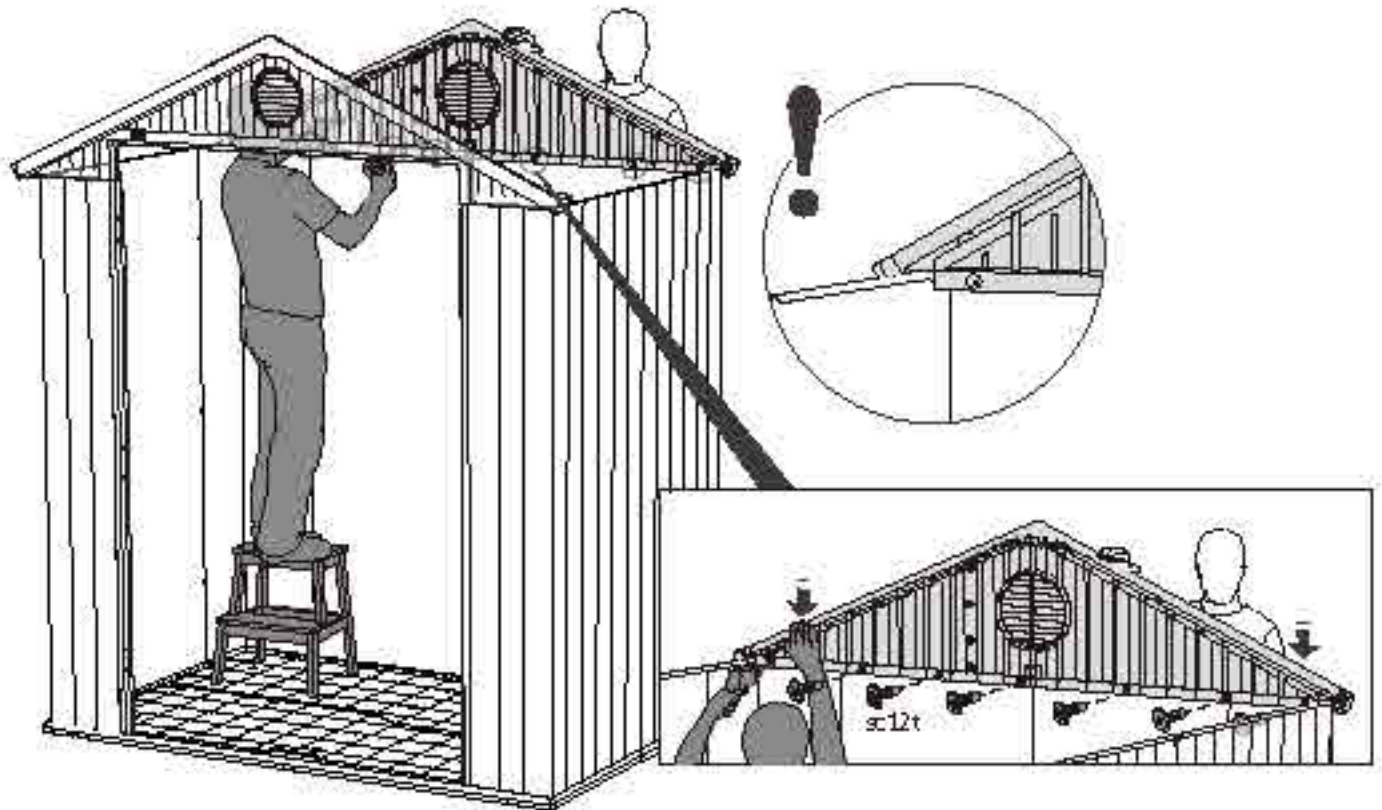
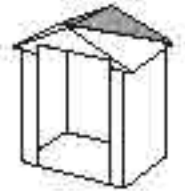

30



DRCB (x1)



sc12t (x4)

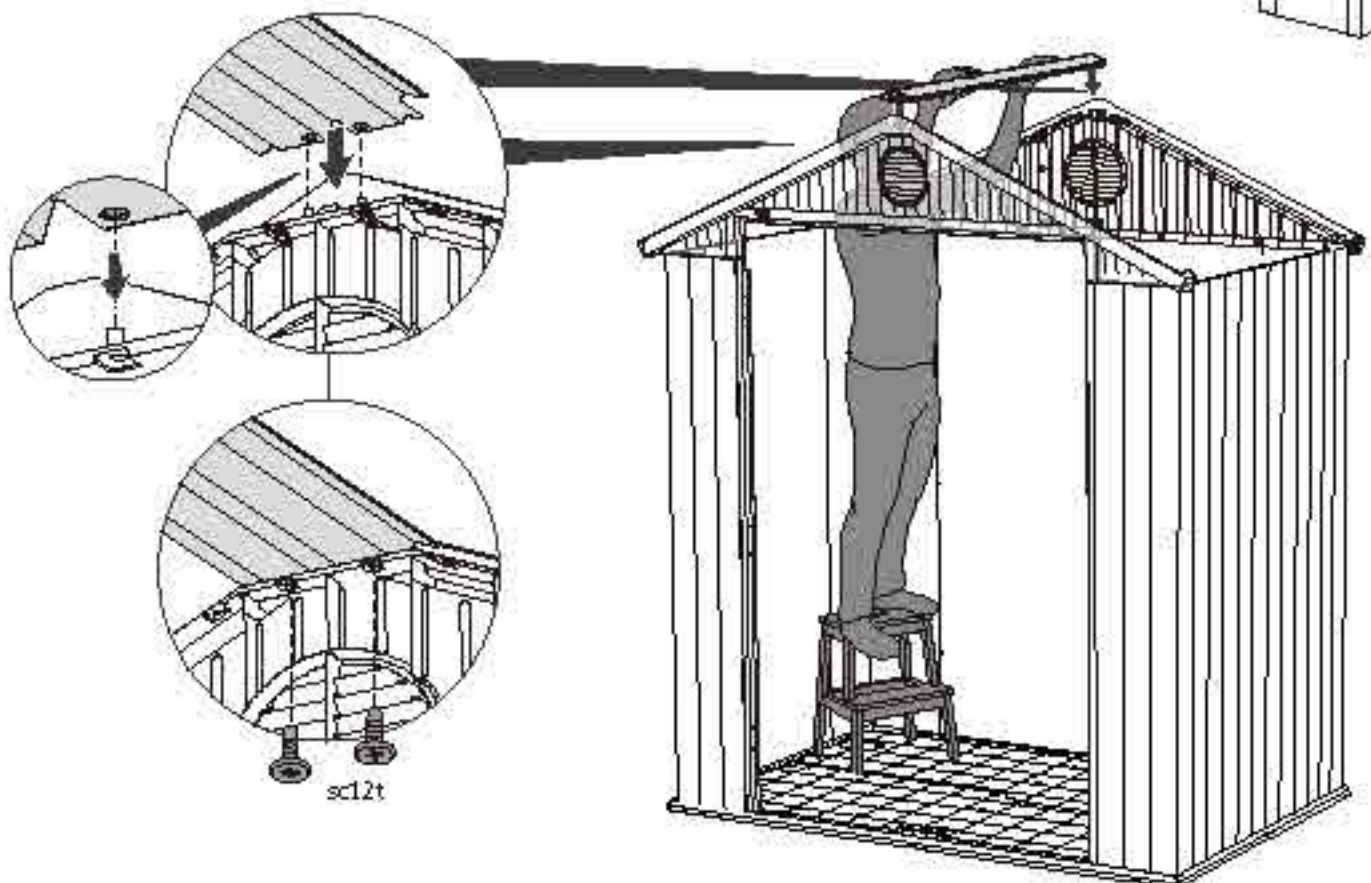
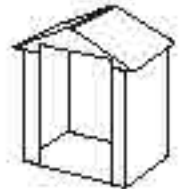

31



DRPM (x2)

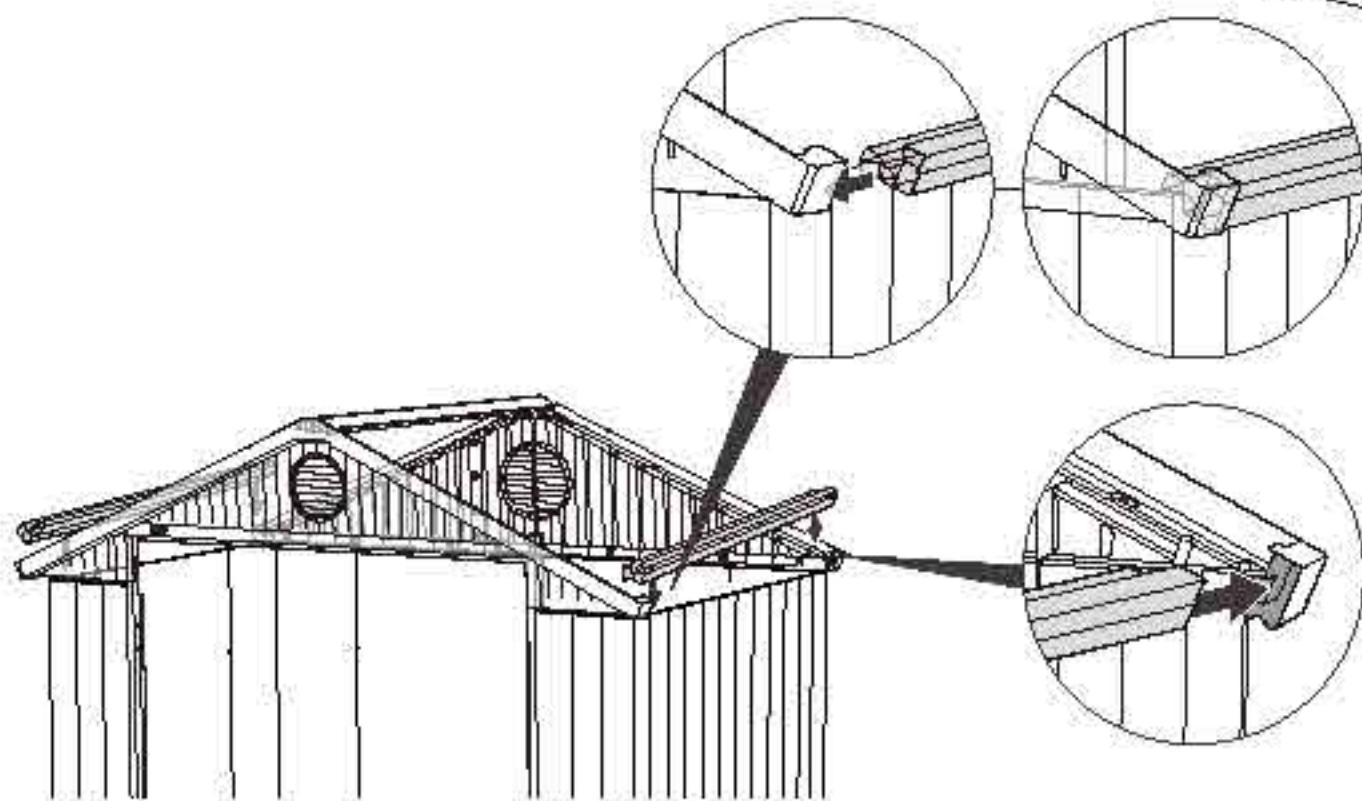
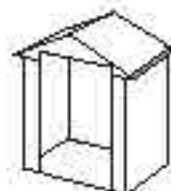

32



DRCC (x4)



sc12t (x4)

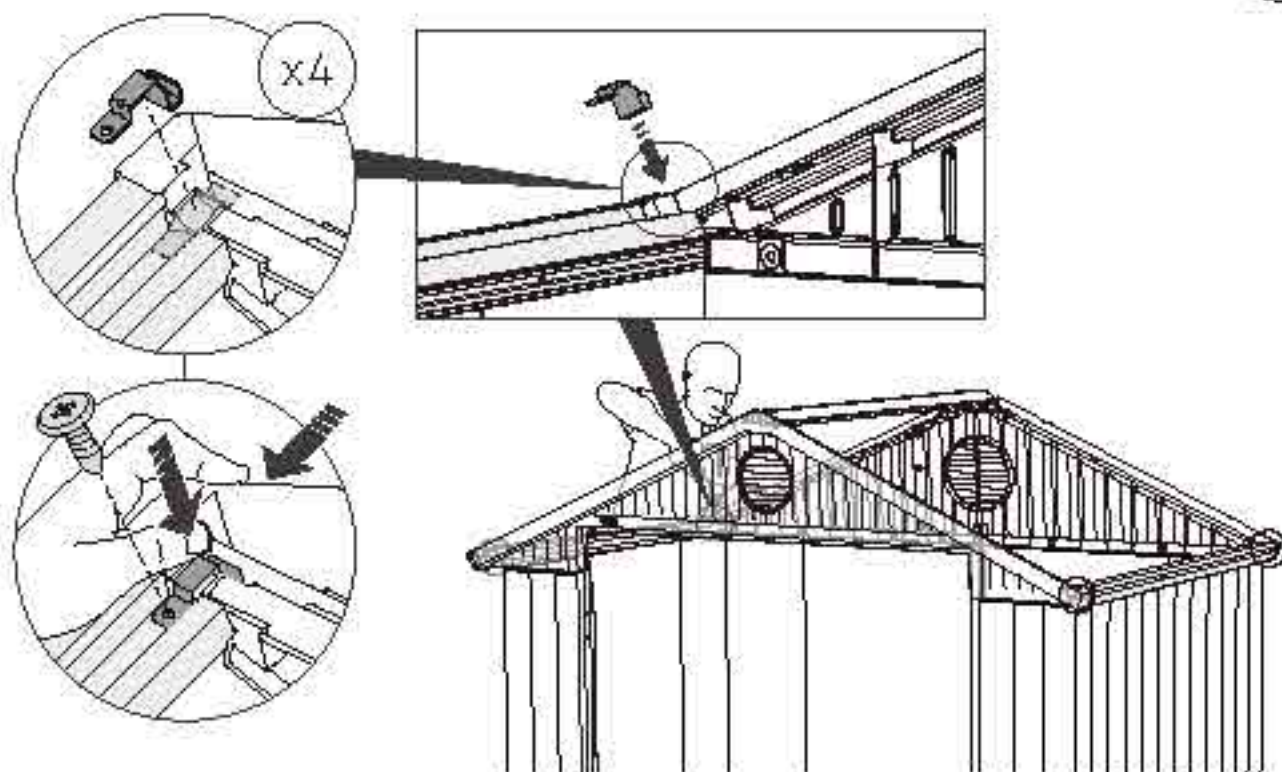
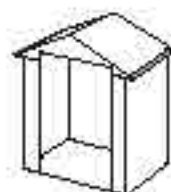

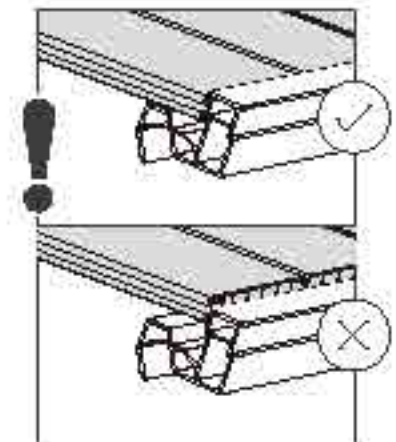
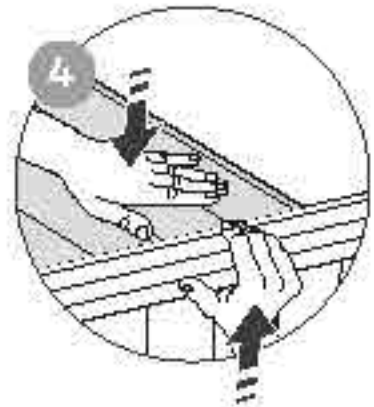
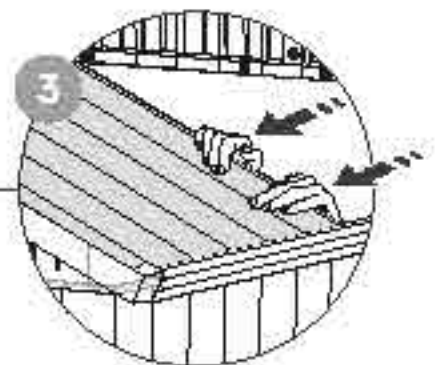
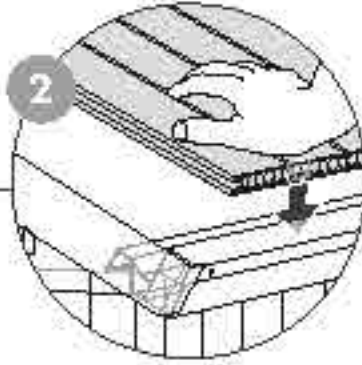
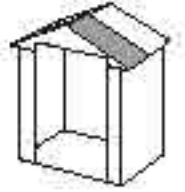

34



sc12t (x2)

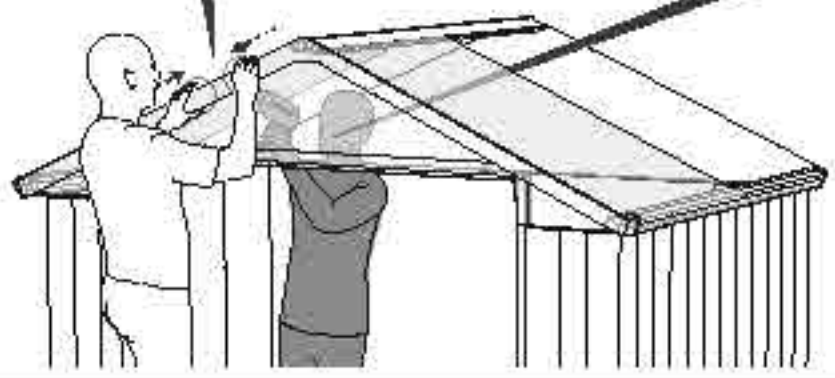
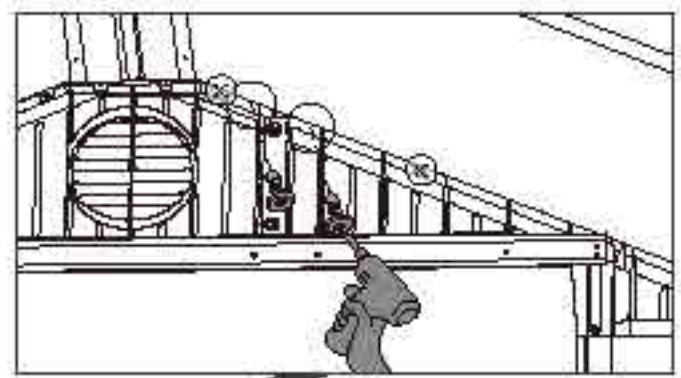

35



sc12t (x6)

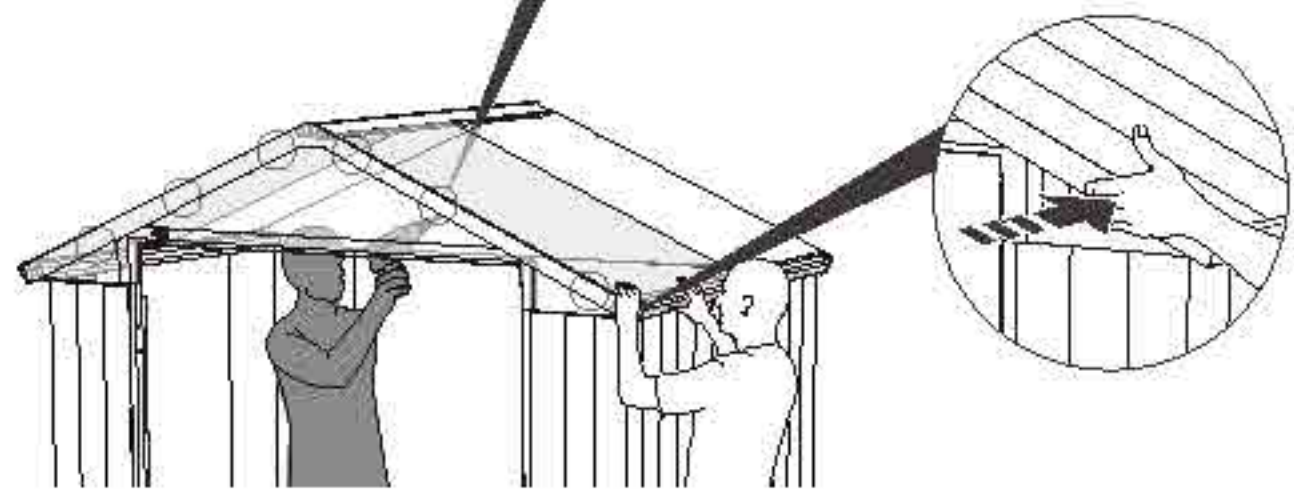
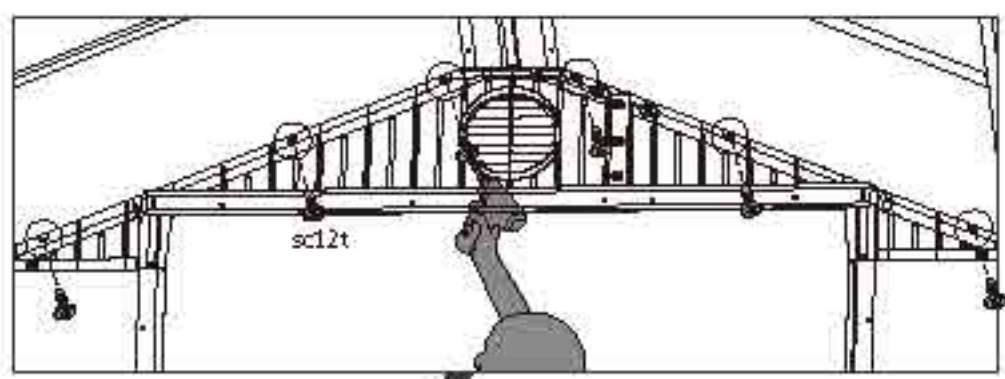
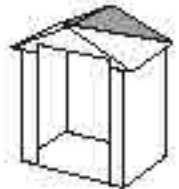

36



DRMDT (x2)

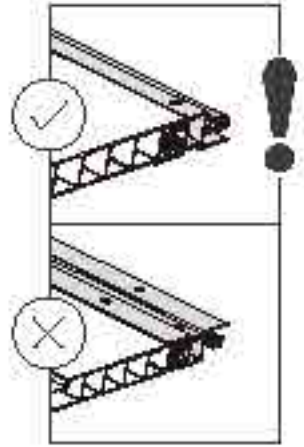
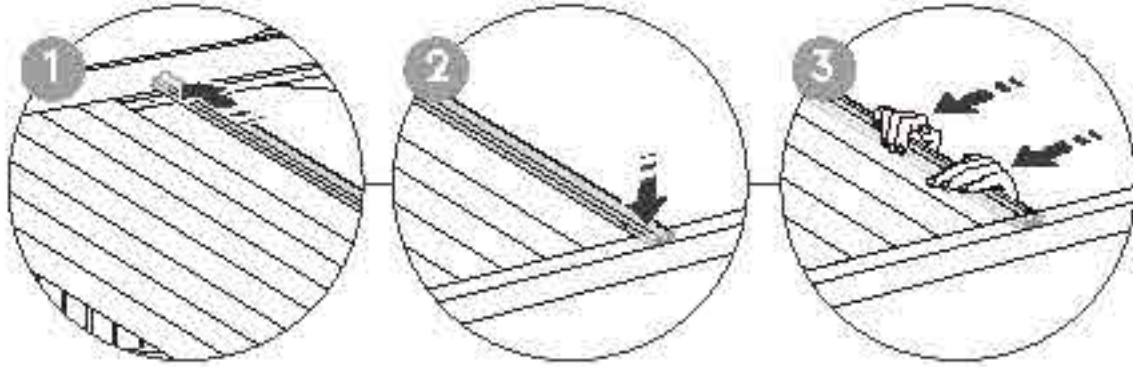

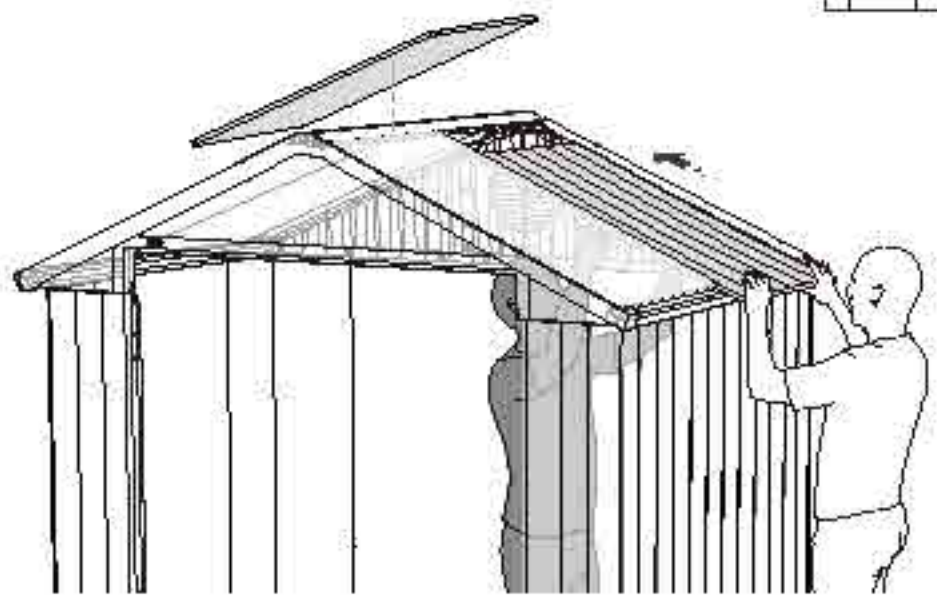
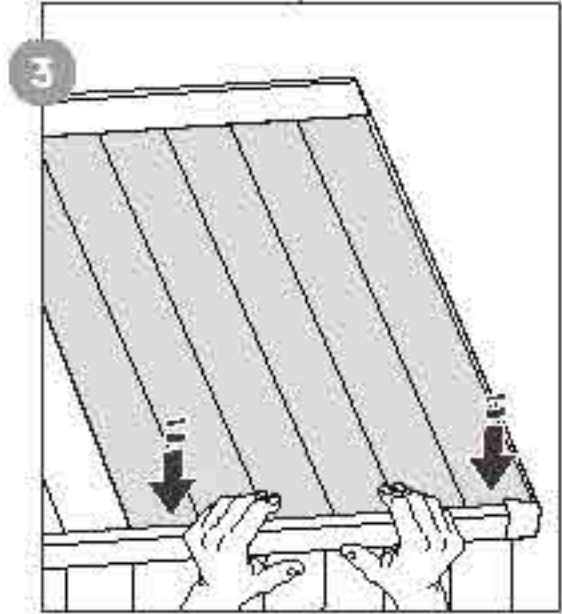
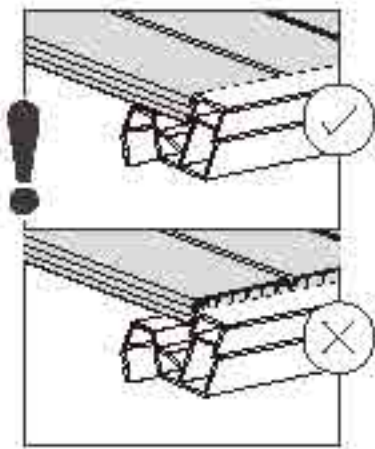
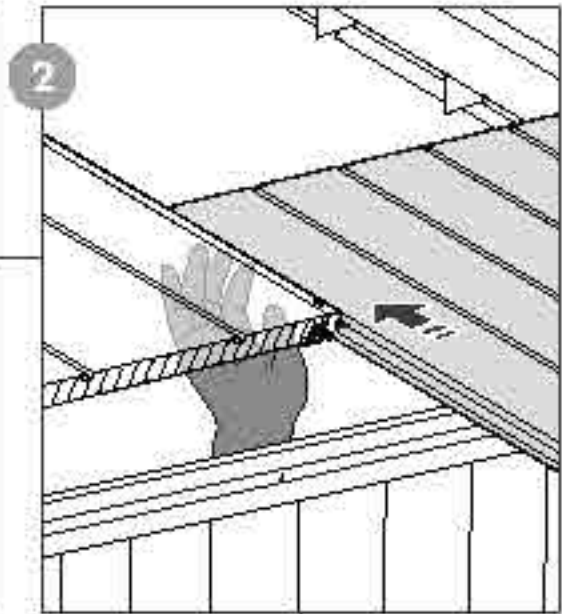
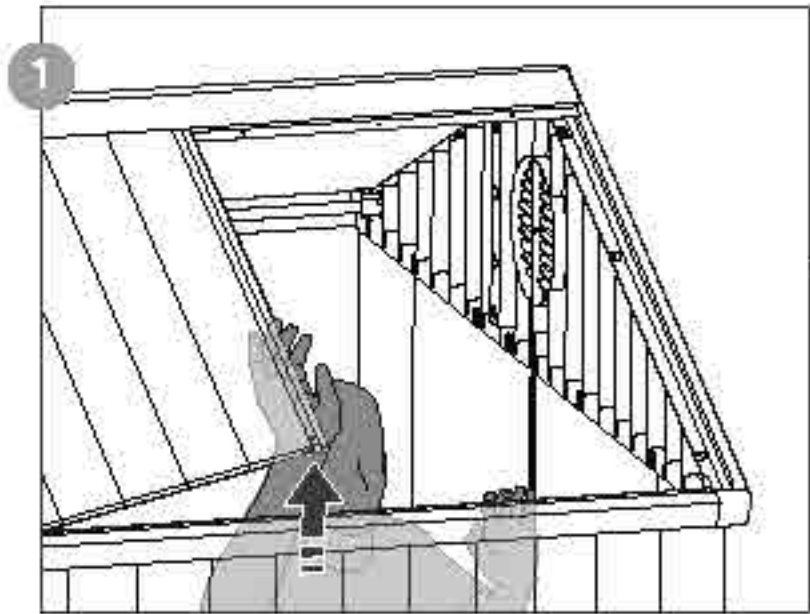
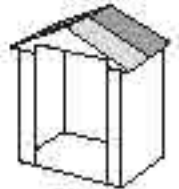

38



sc12t (x2)

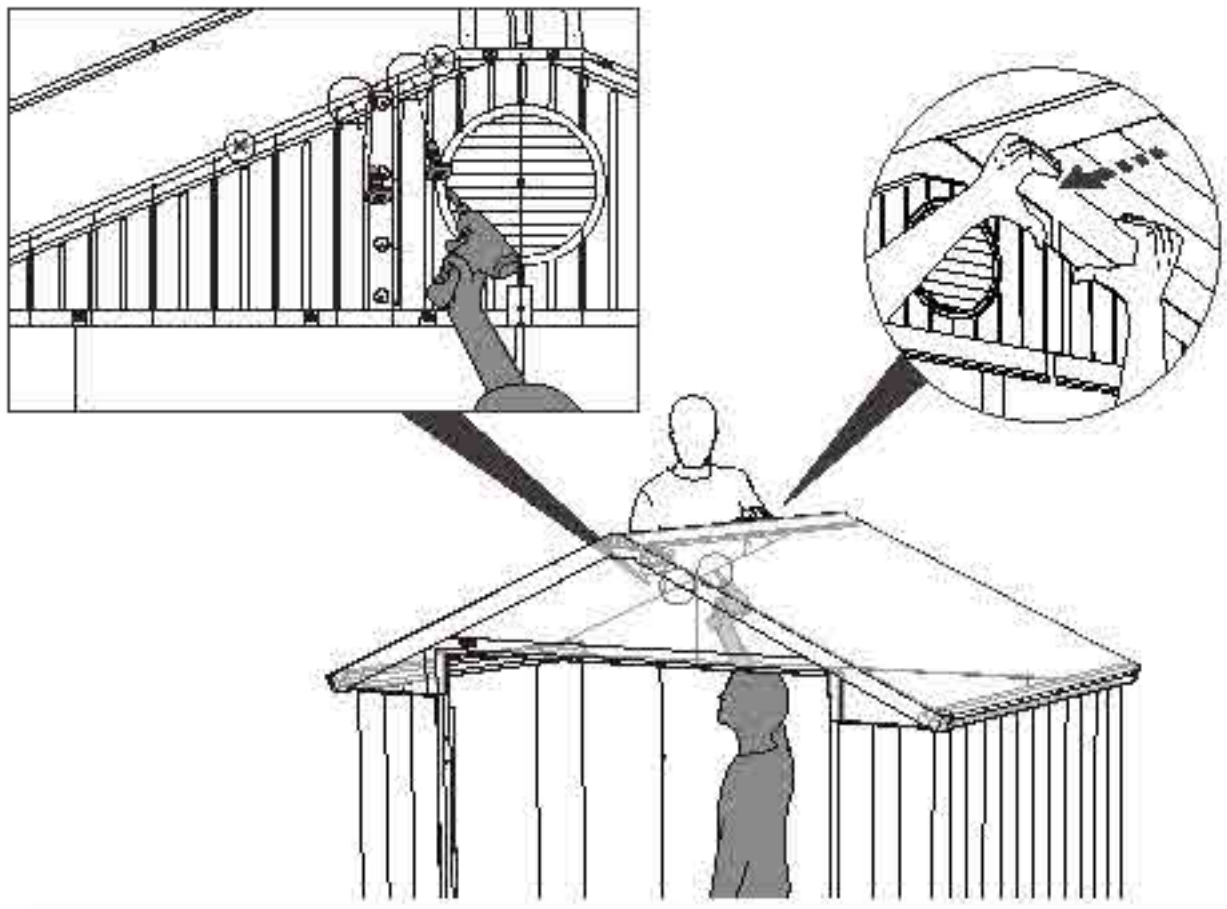

39



sc12t (x6)

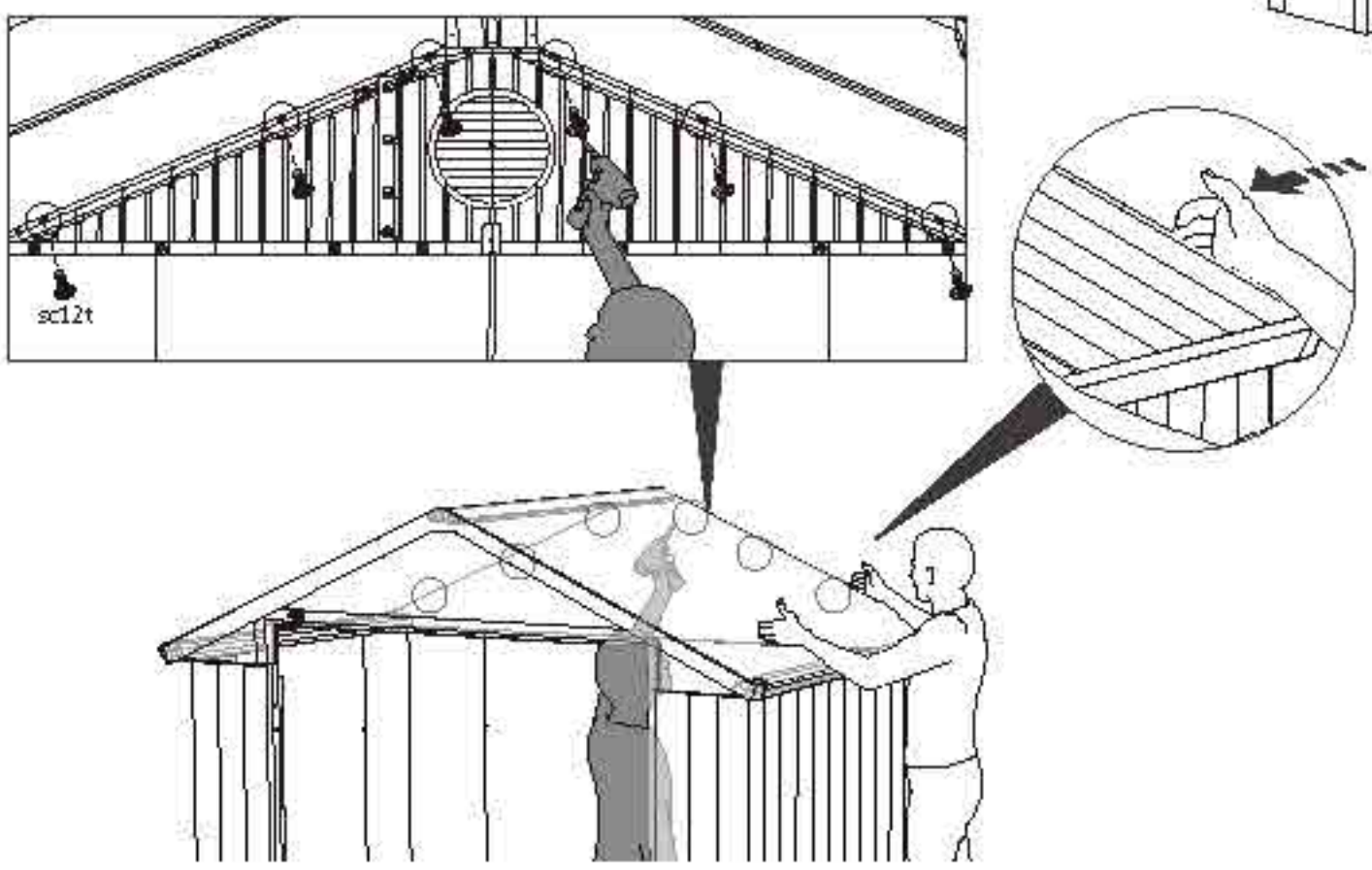
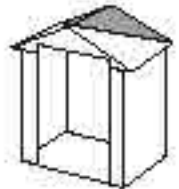

40

 sc36 (x2)

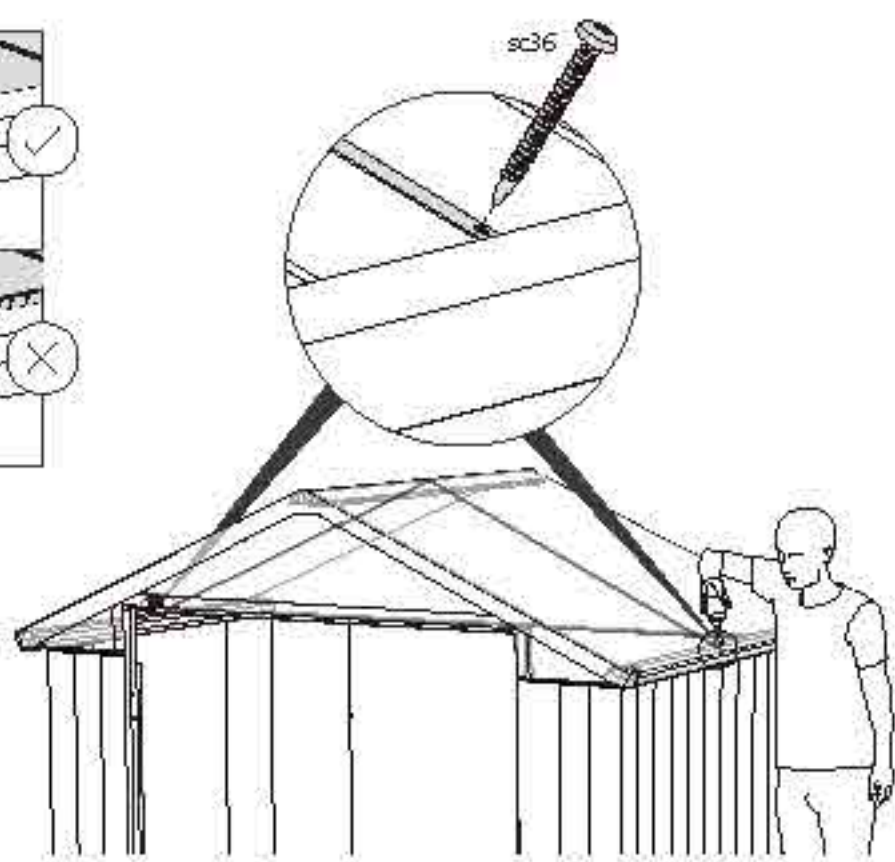
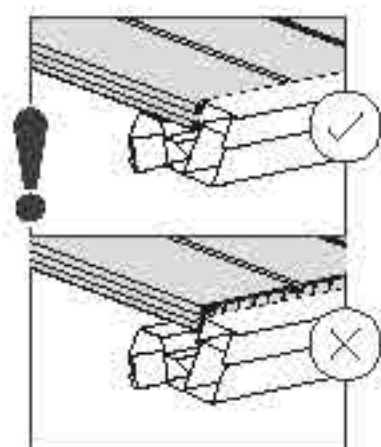
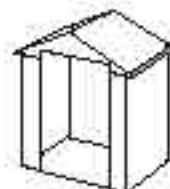

41

 sc12t (x8)

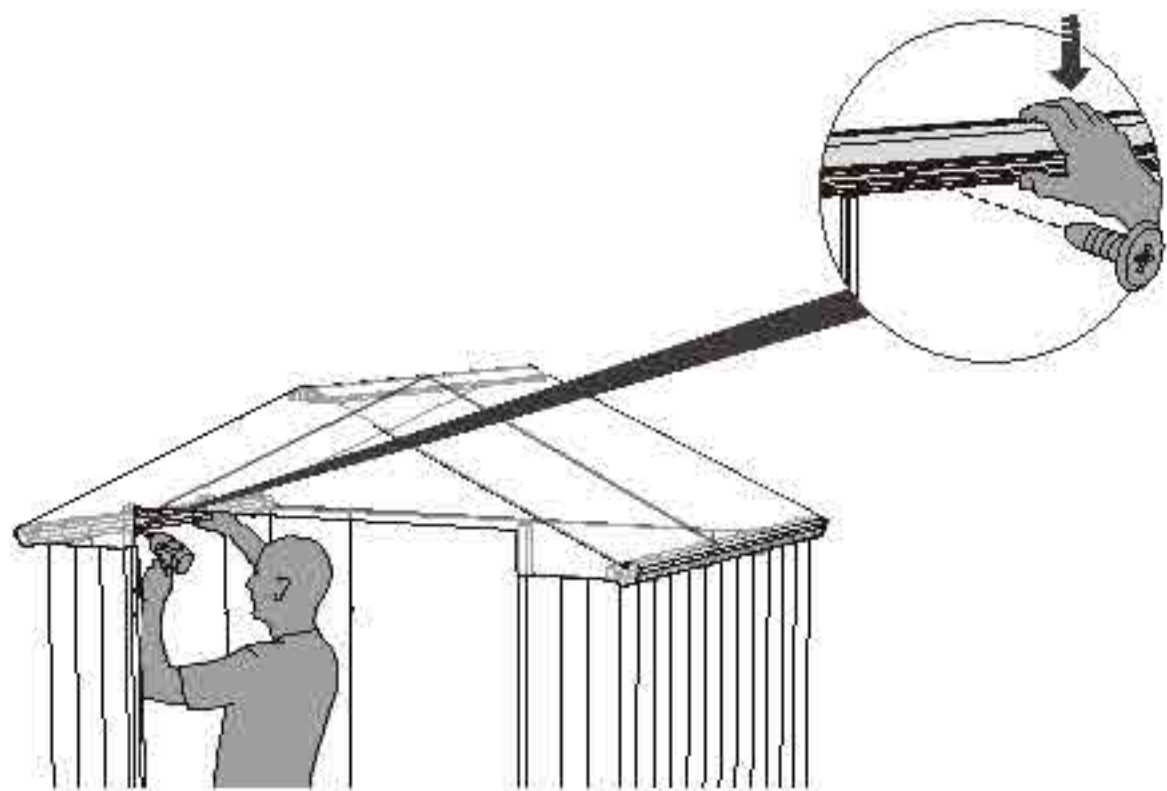
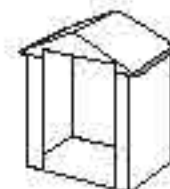

42

 sc12t (x12)

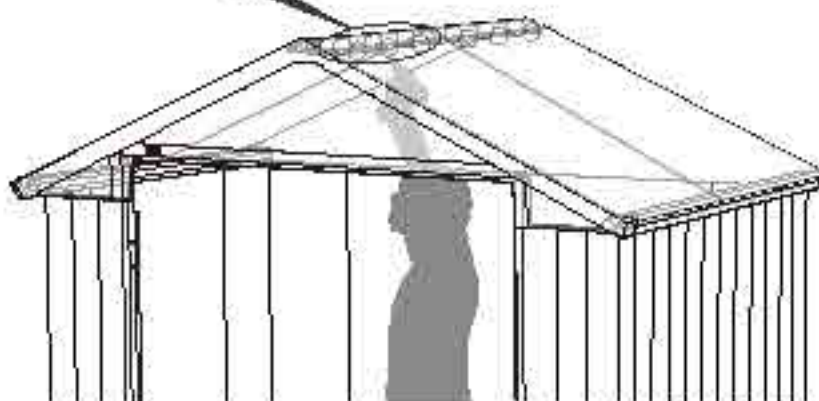
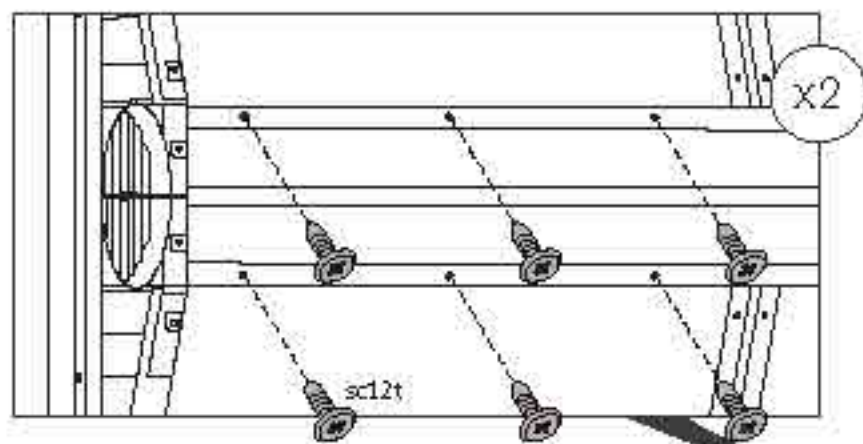
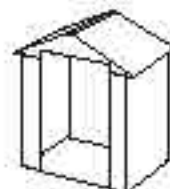

43

 sc7t (x12)

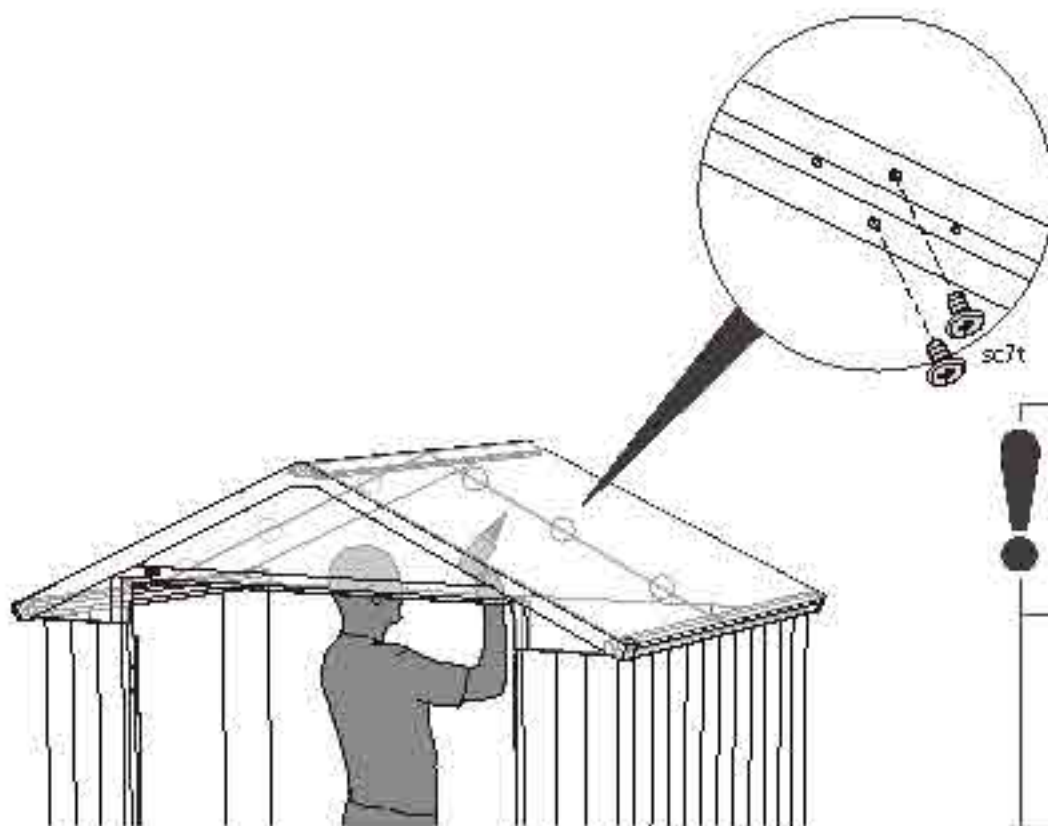
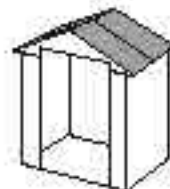

44

sc12t (x16)

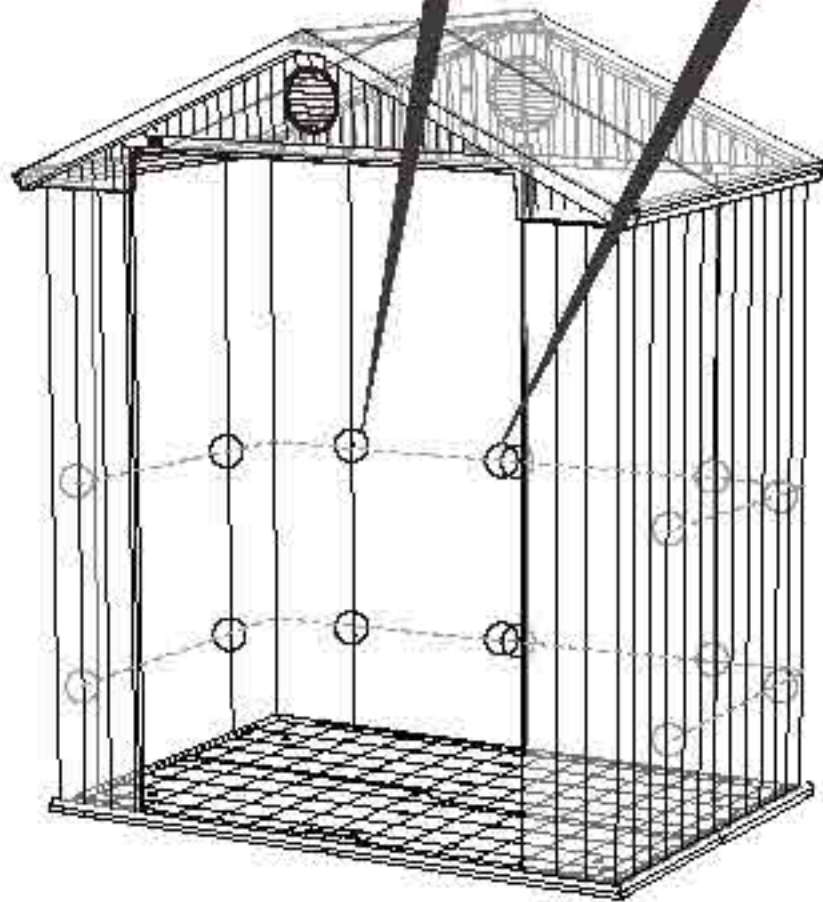
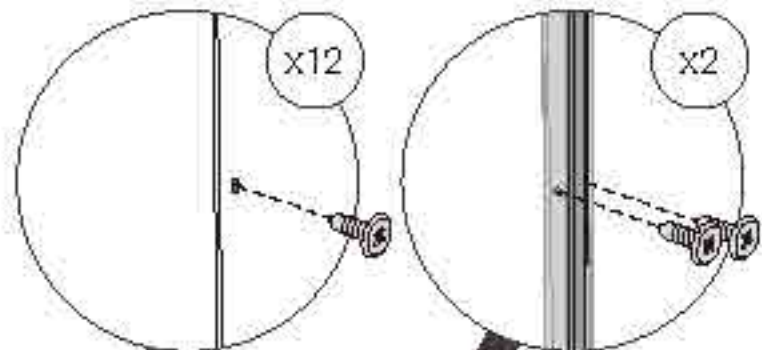
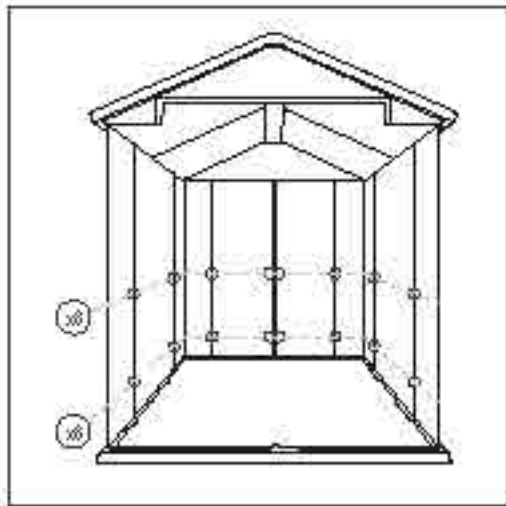

45



DRWMP (x1)



sc12t (x1)

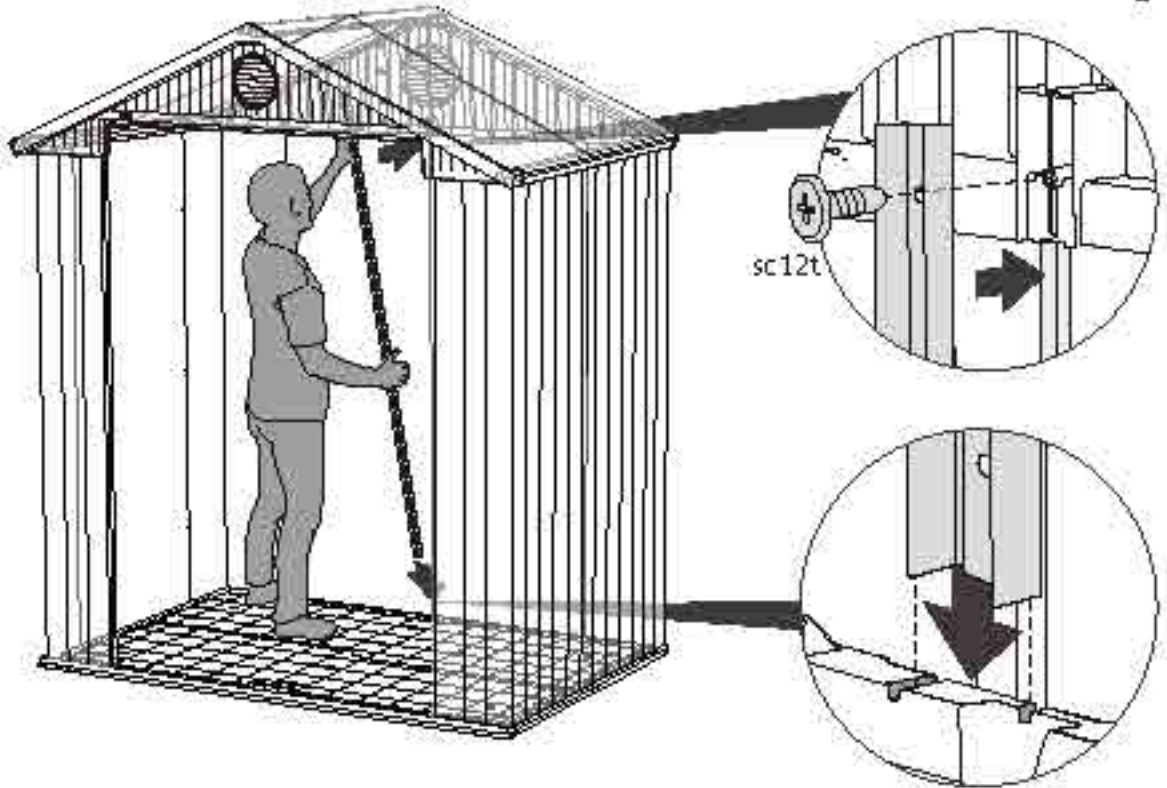

46



sc12t (x3)

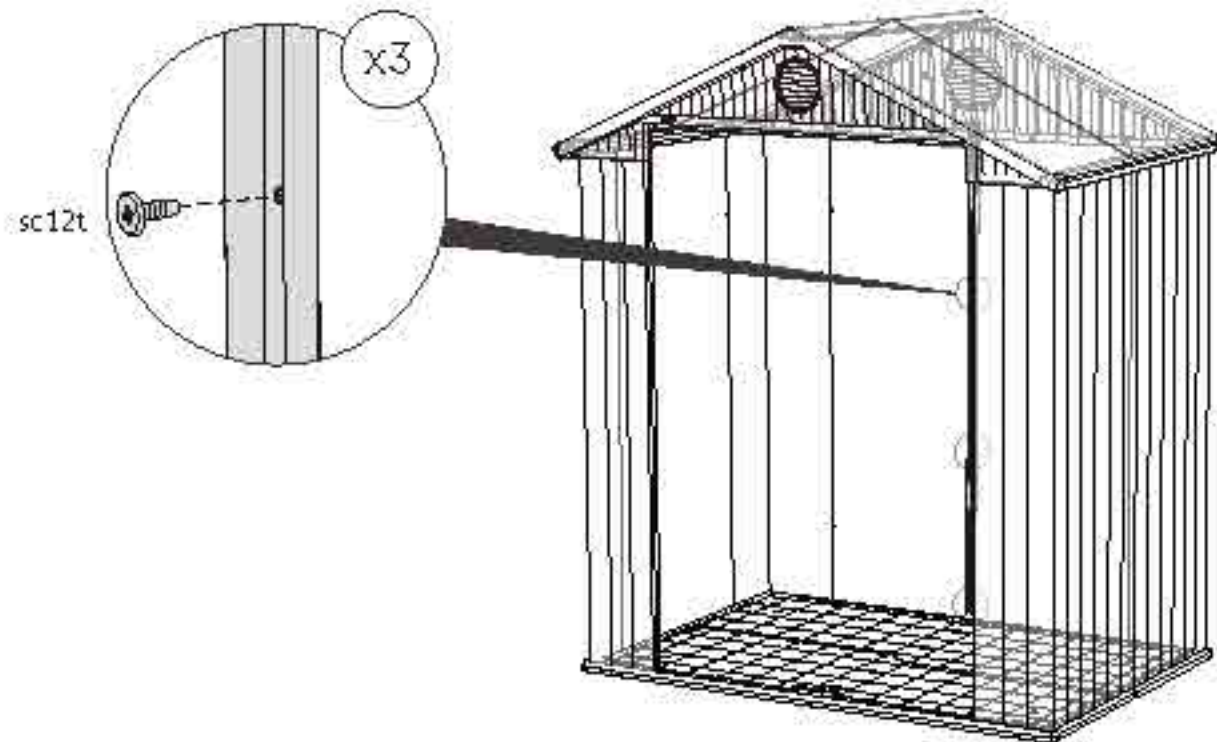

47



d6BP (x1)



sc12t (x4)

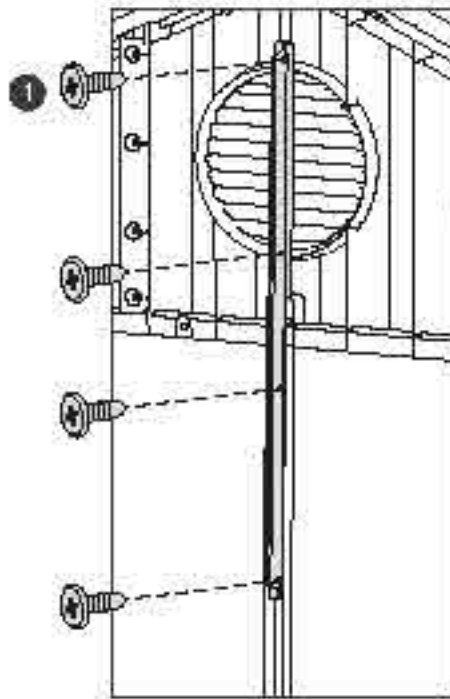

48

 sc36 (x8)

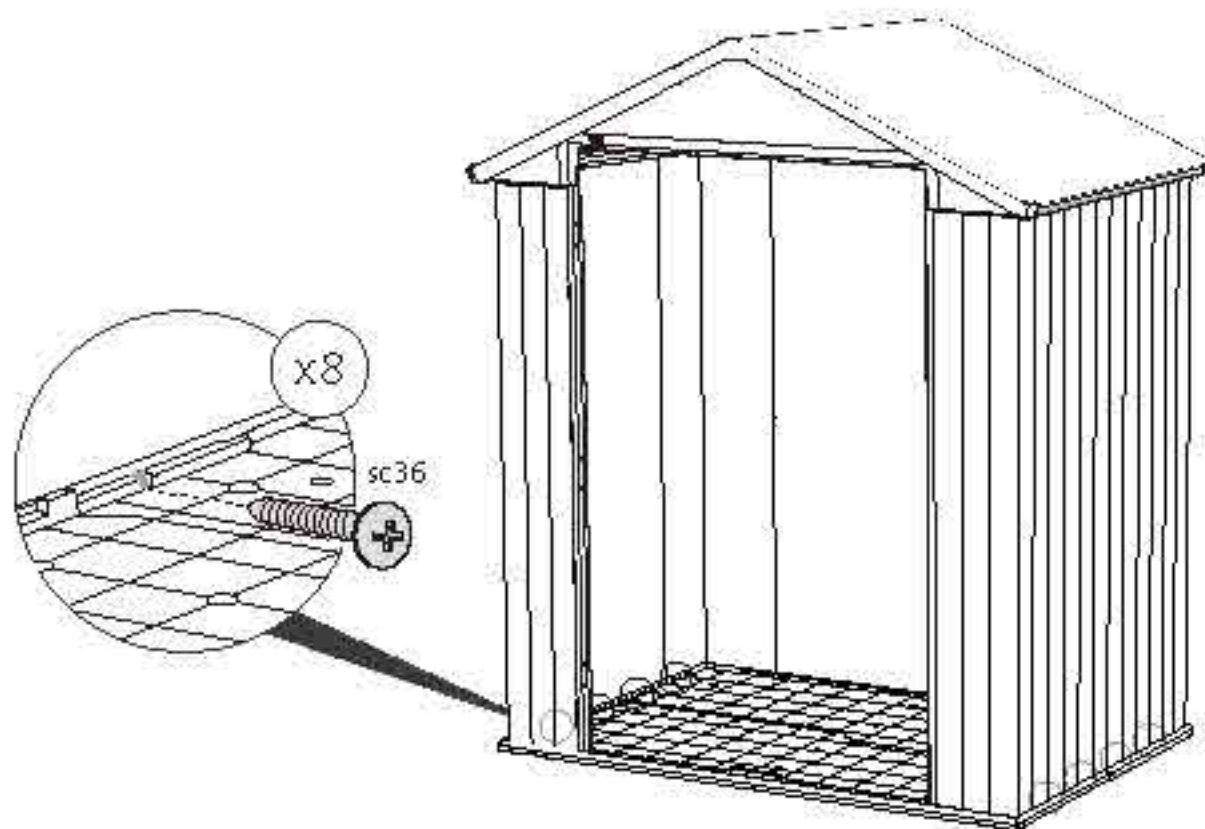
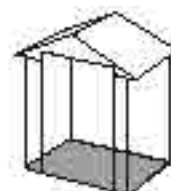

49

 sc36 (x8)

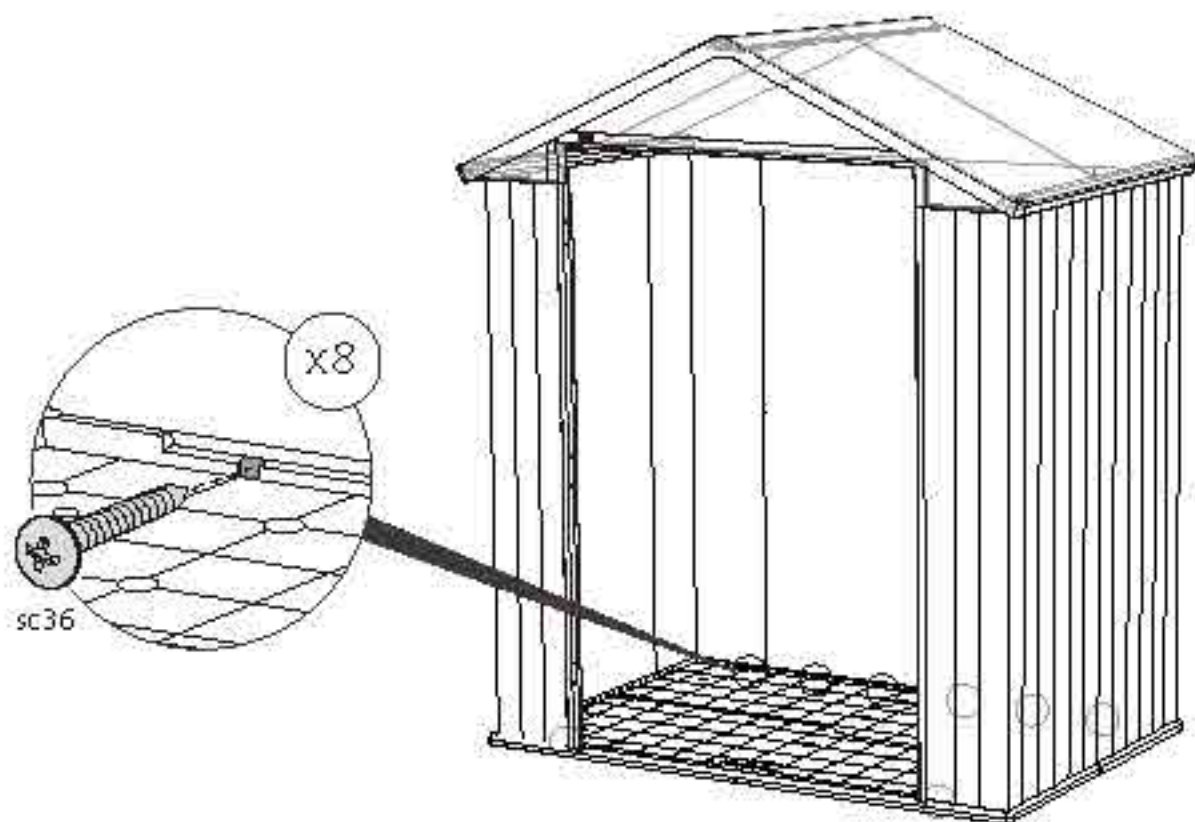

50



DRPD (x4)

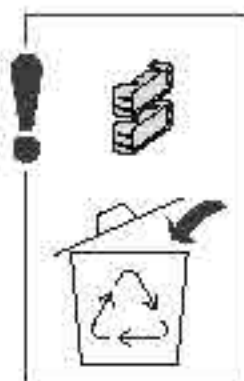
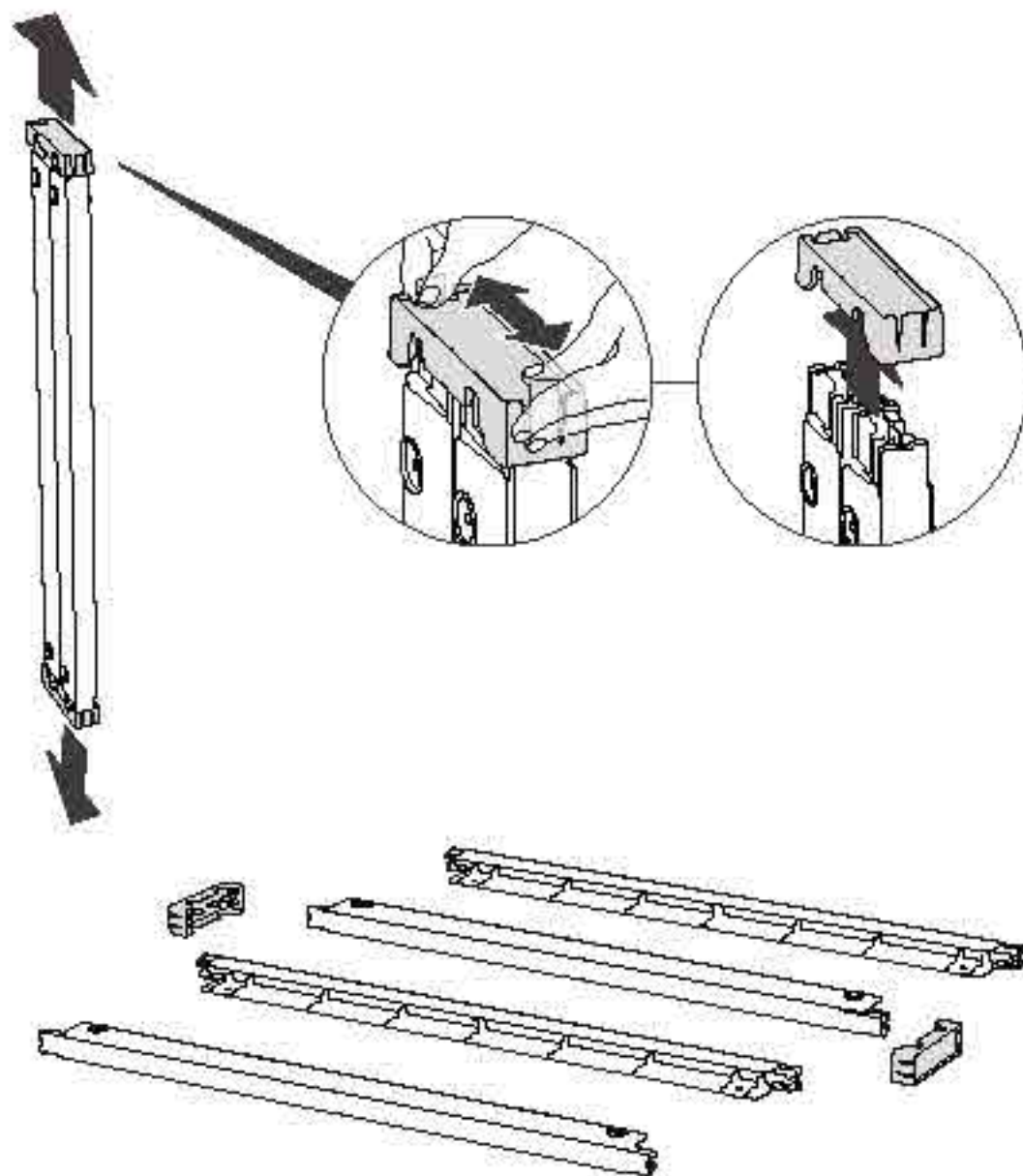
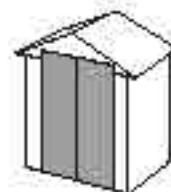

51



DR6D (x2)



DRPD (x4)

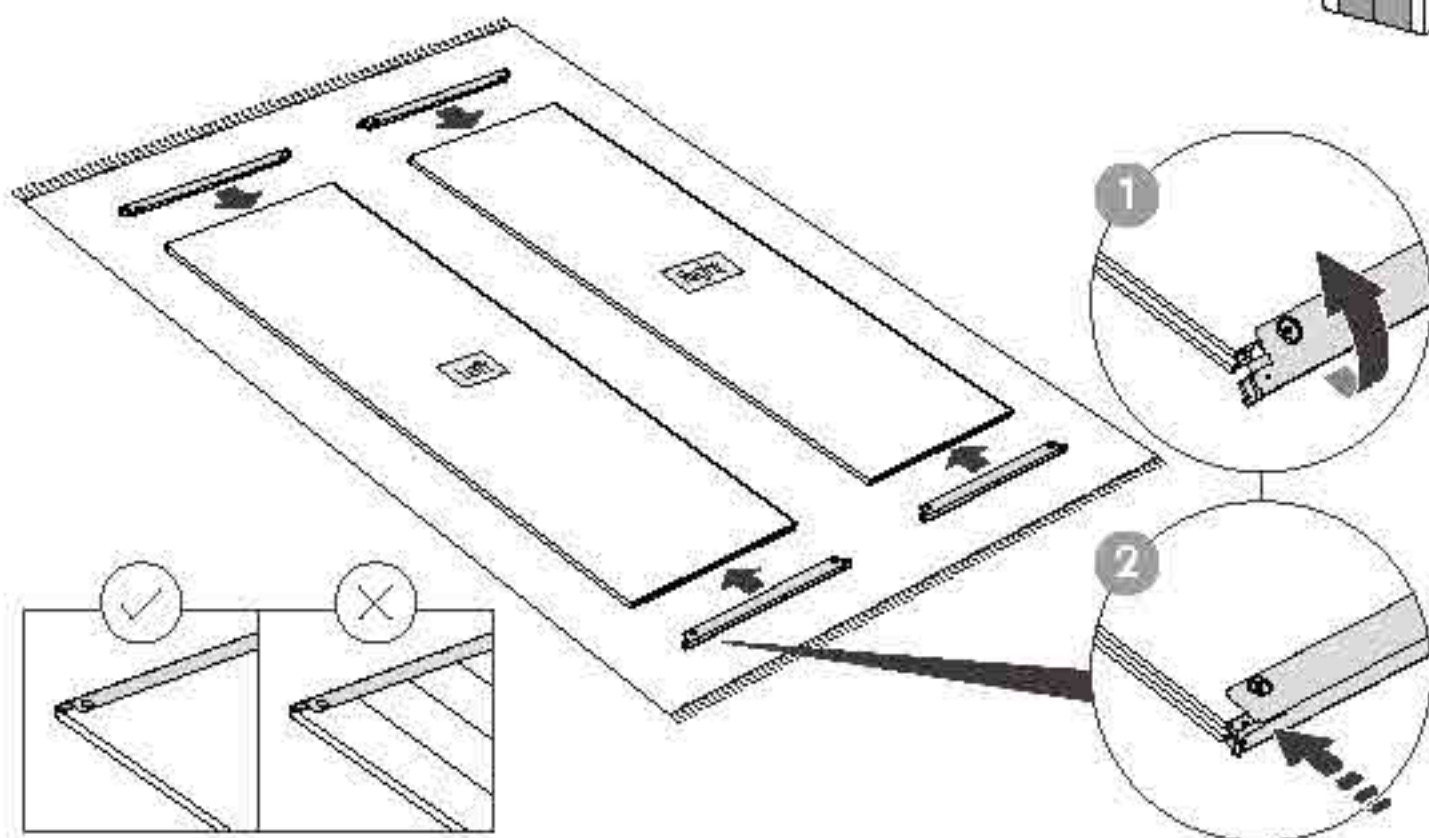

52



DRMA (x3)



DRMW (x1)

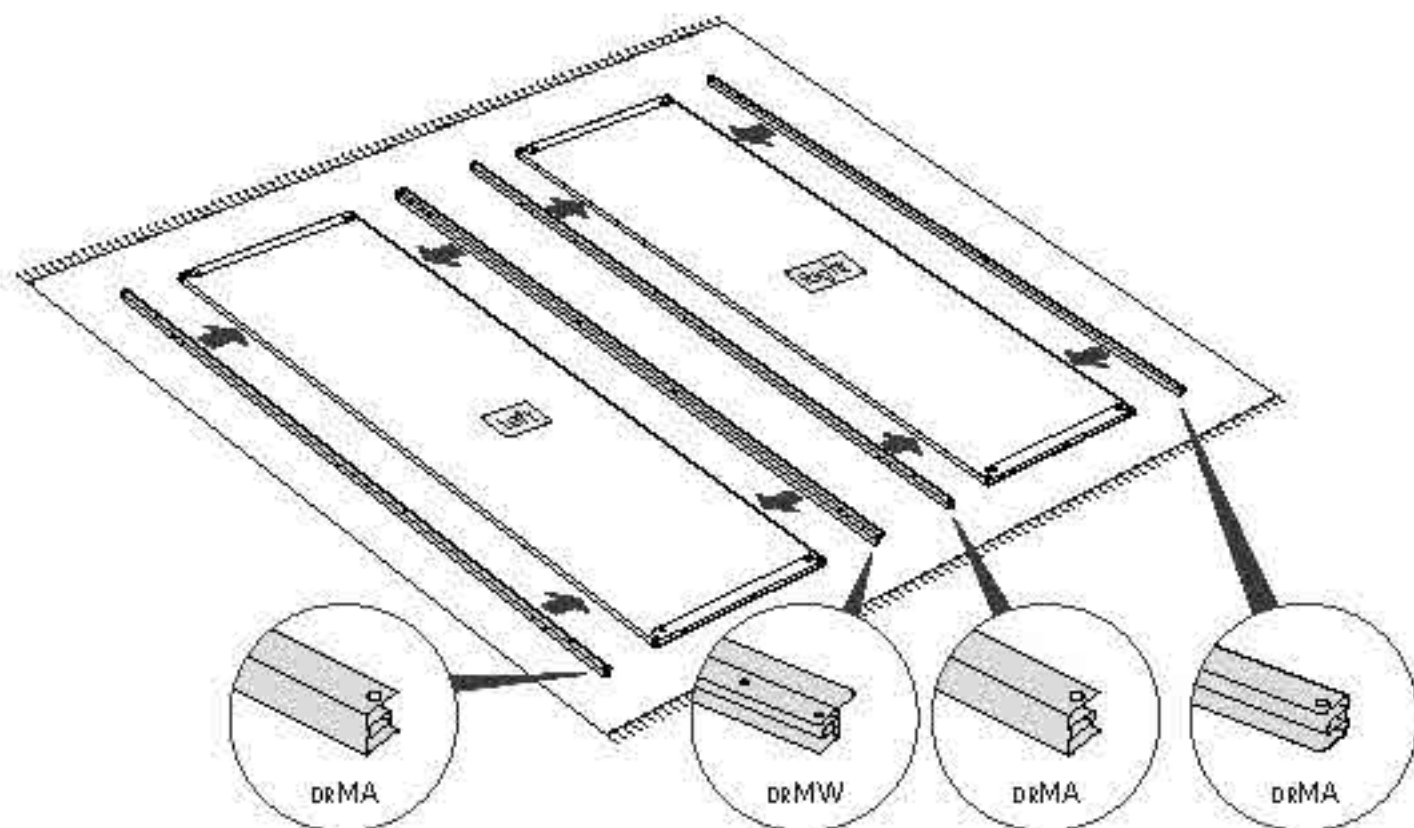
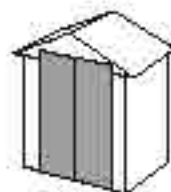

53

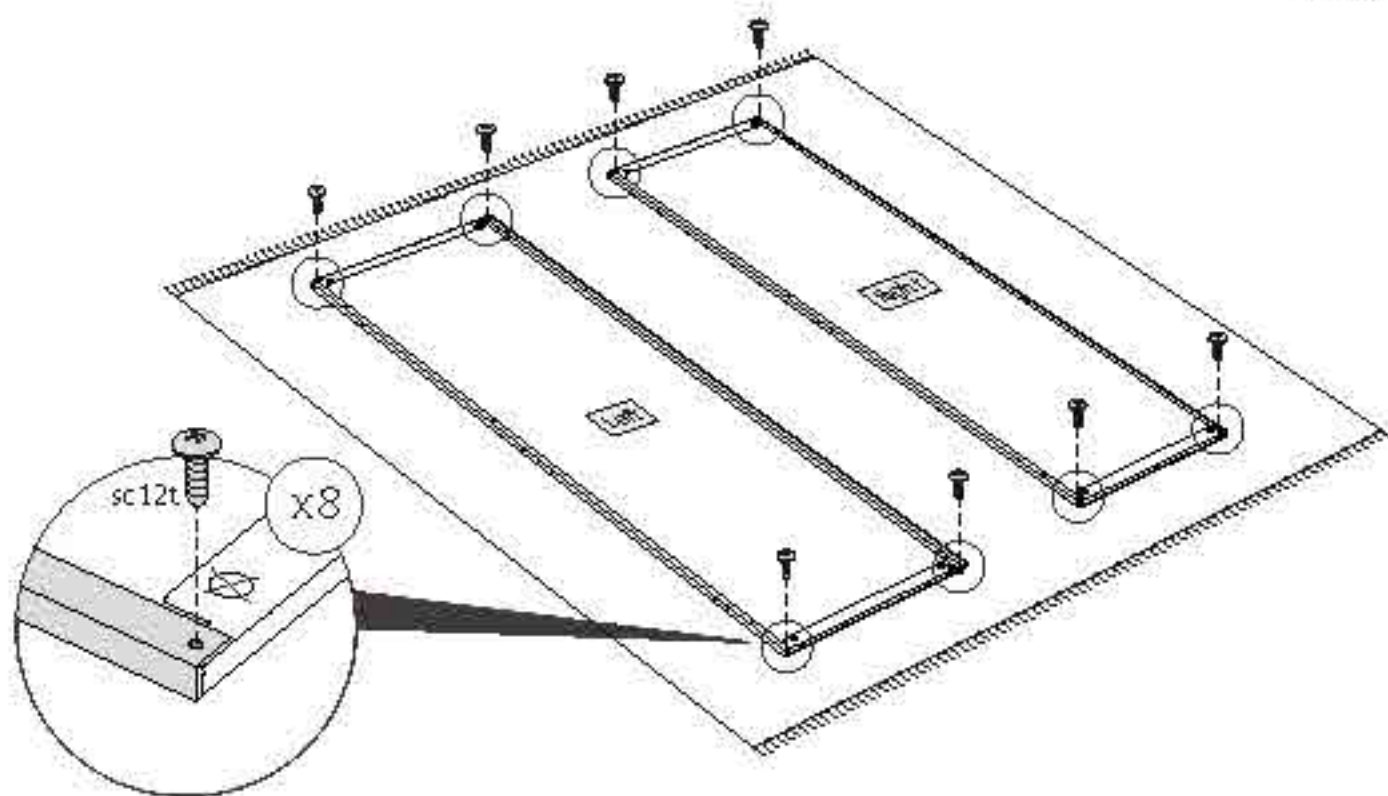
 sc12t (x8)

54

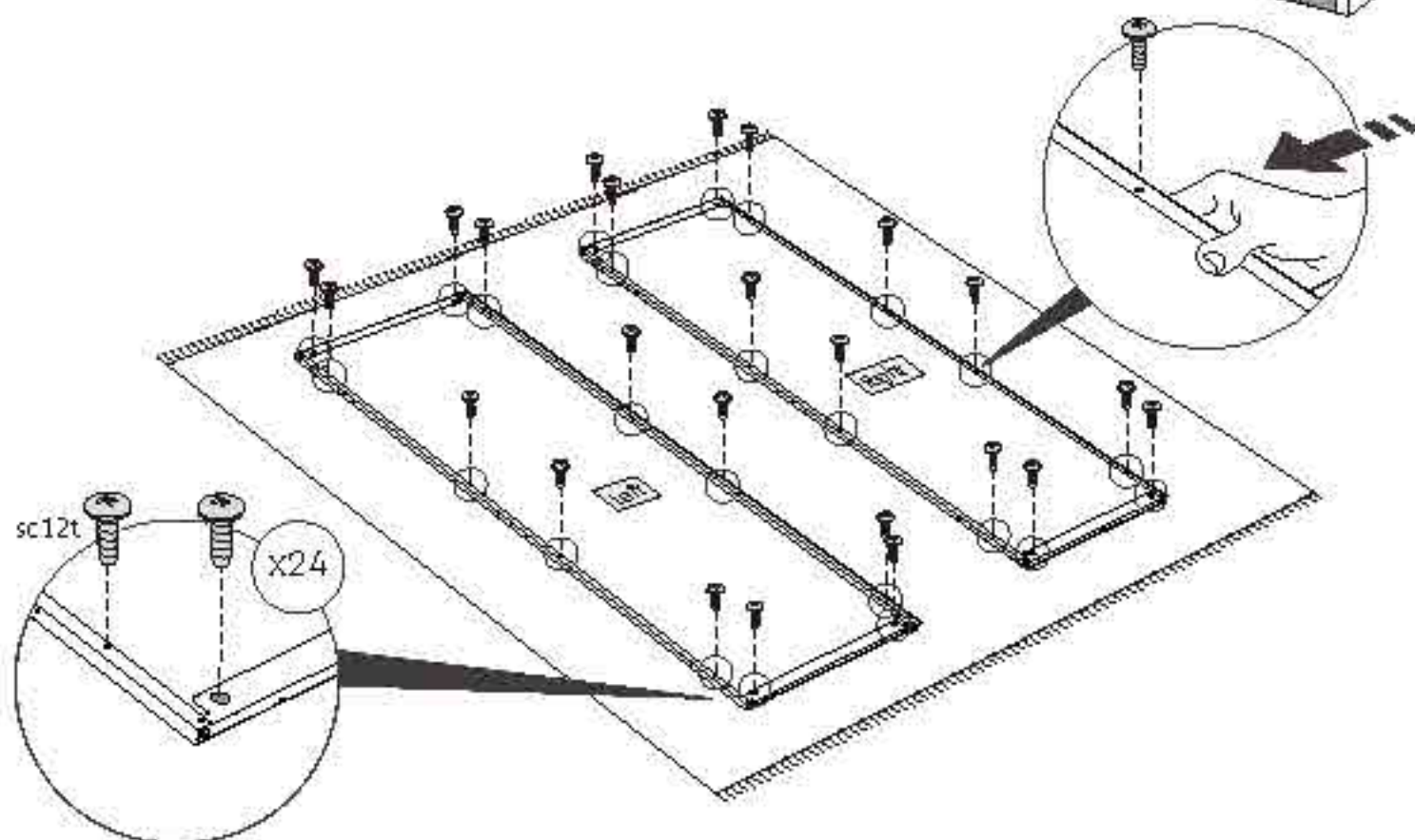
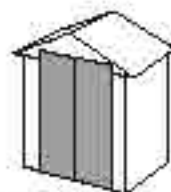
 sc12t (x24)

55

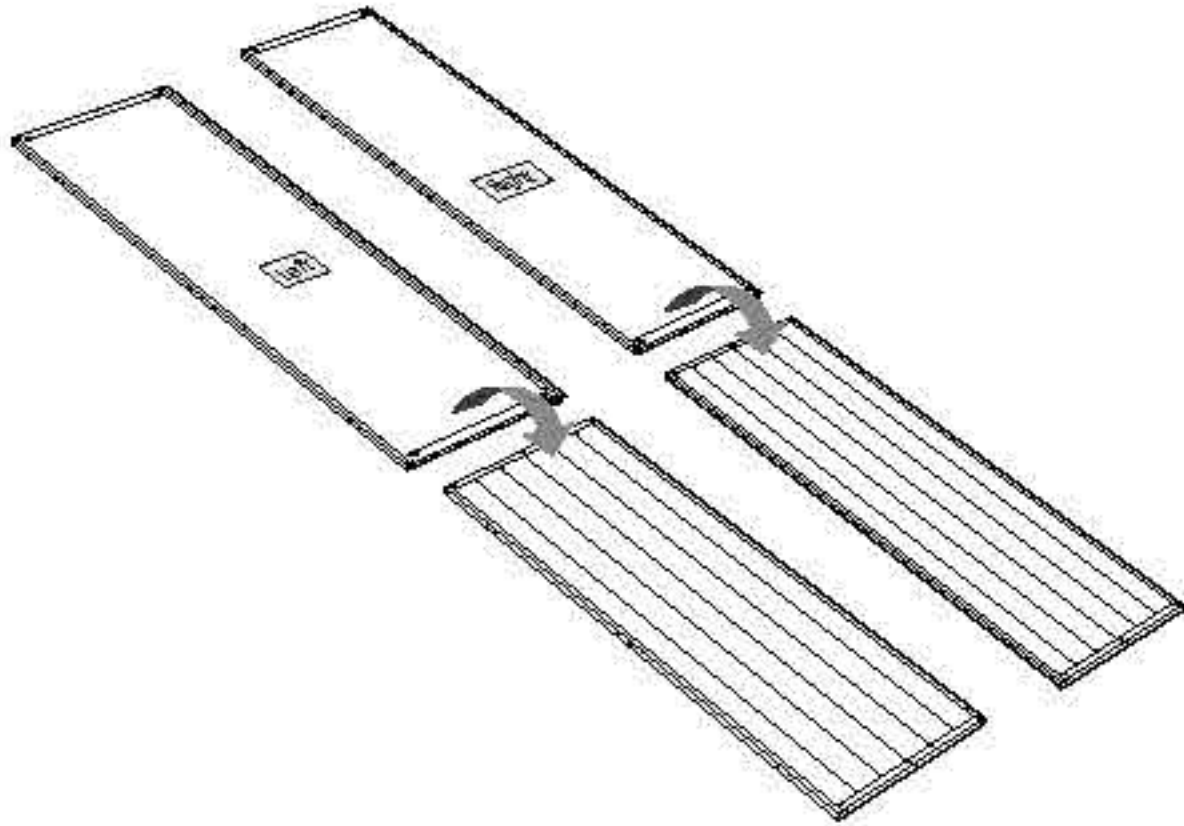
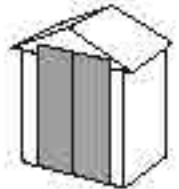

56



DRHG (x4)



sw15d (x8)

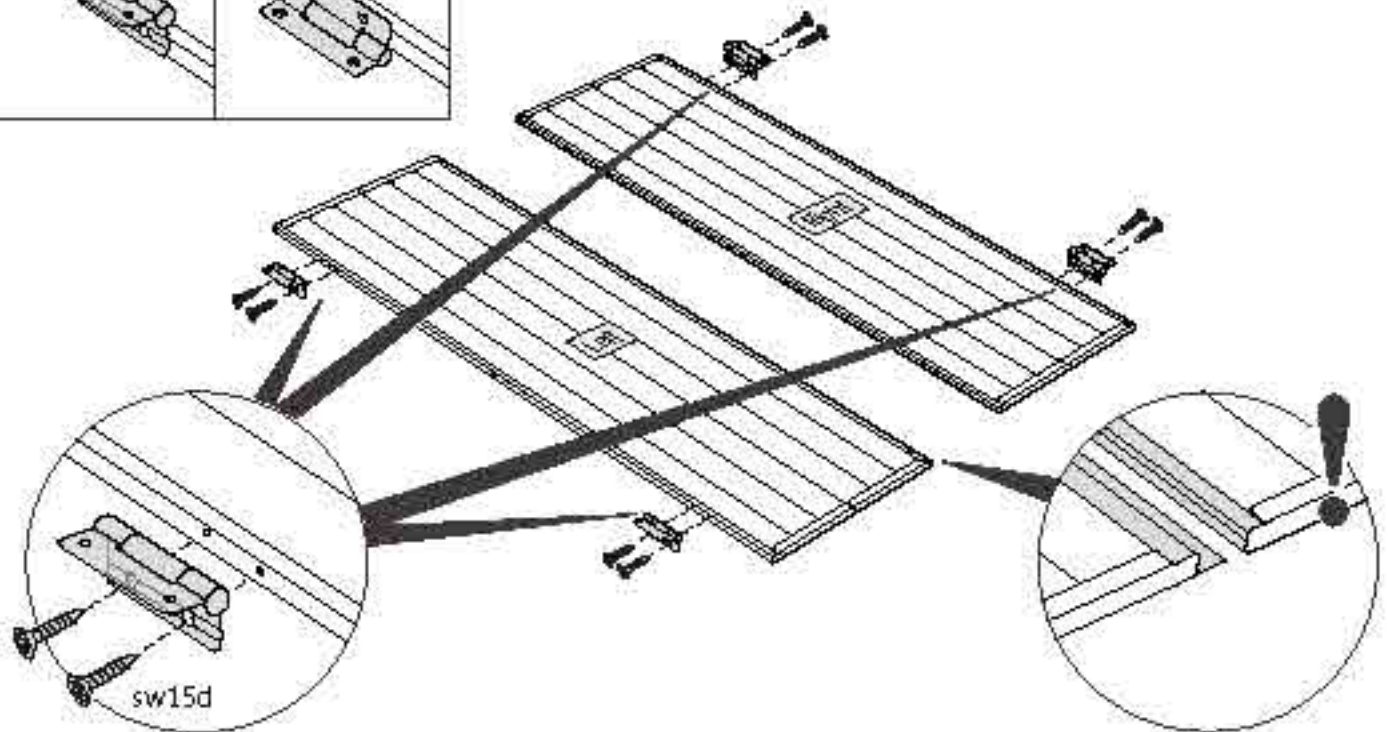
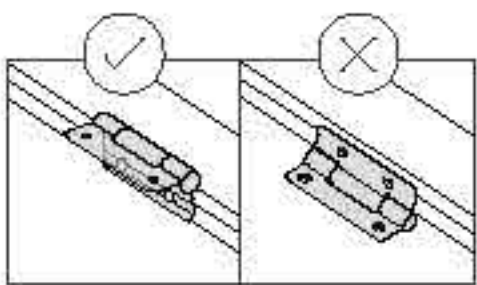
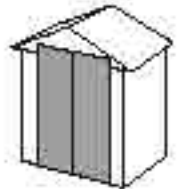

57



sw15d (x8)

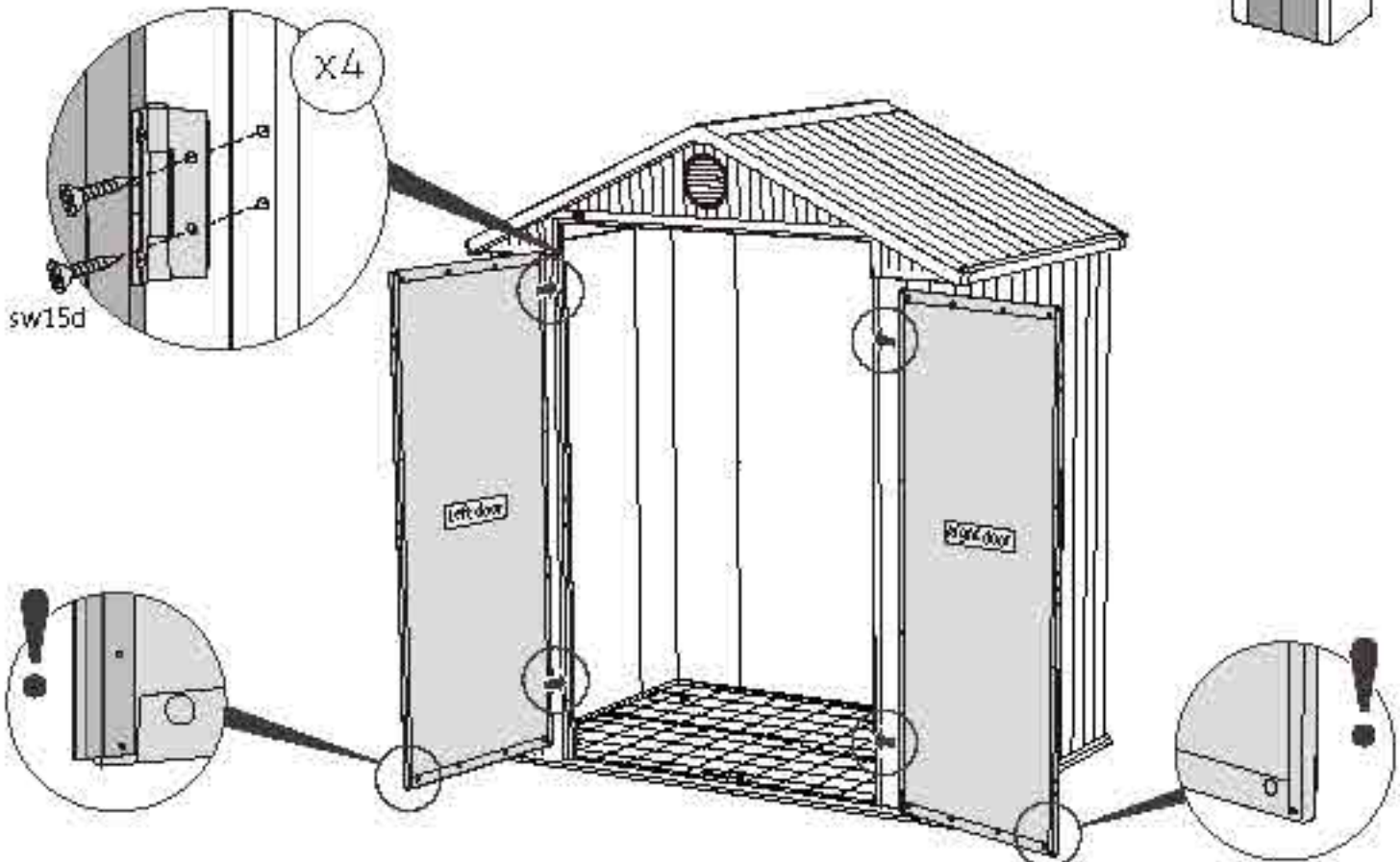
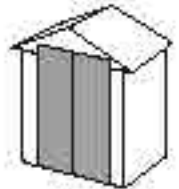

58



DRLH (x1)



DRLM (x1)



sw15d (x5)

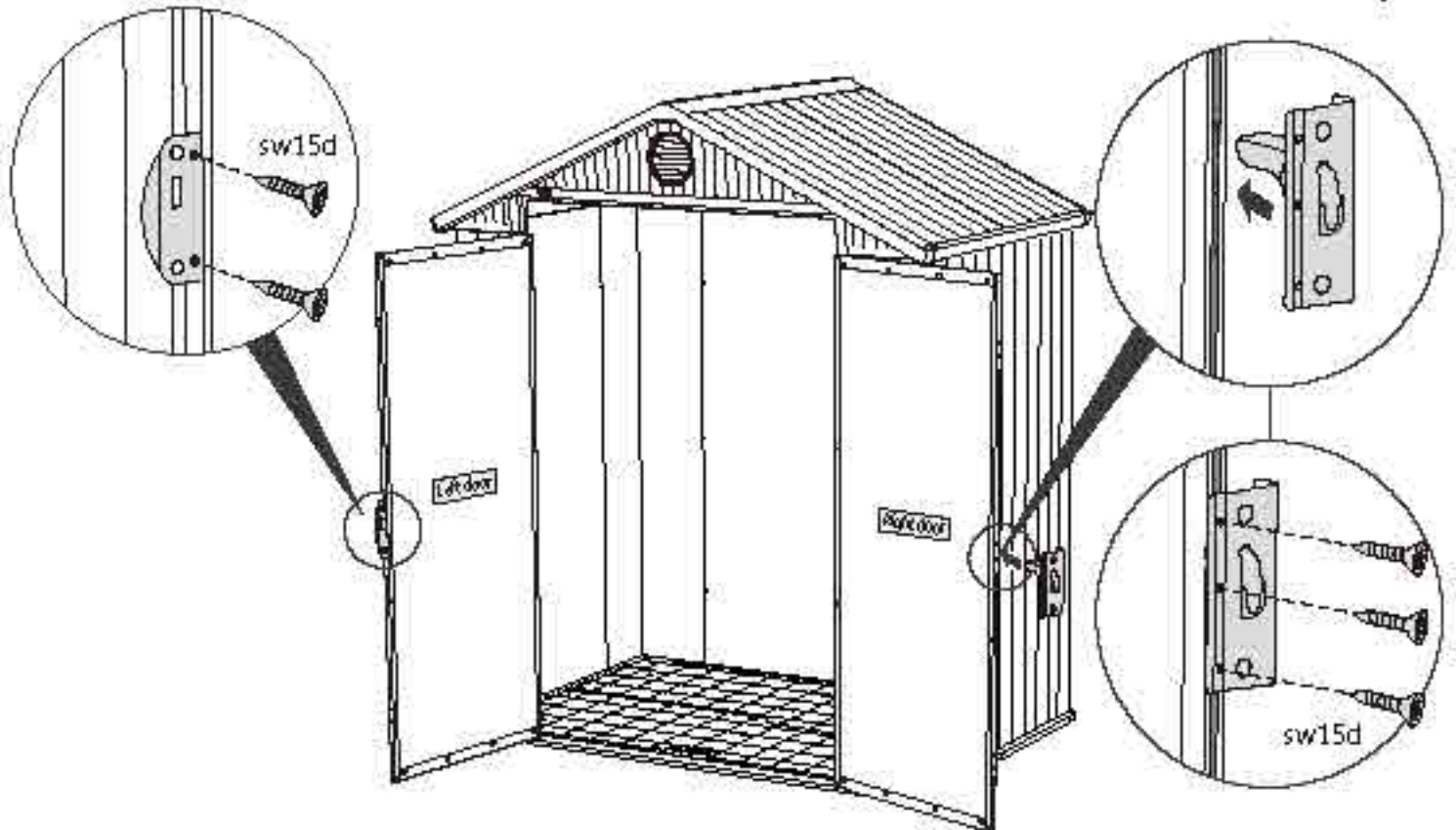
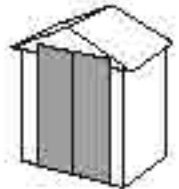

59



D&L (x2)



sw15d (x4)

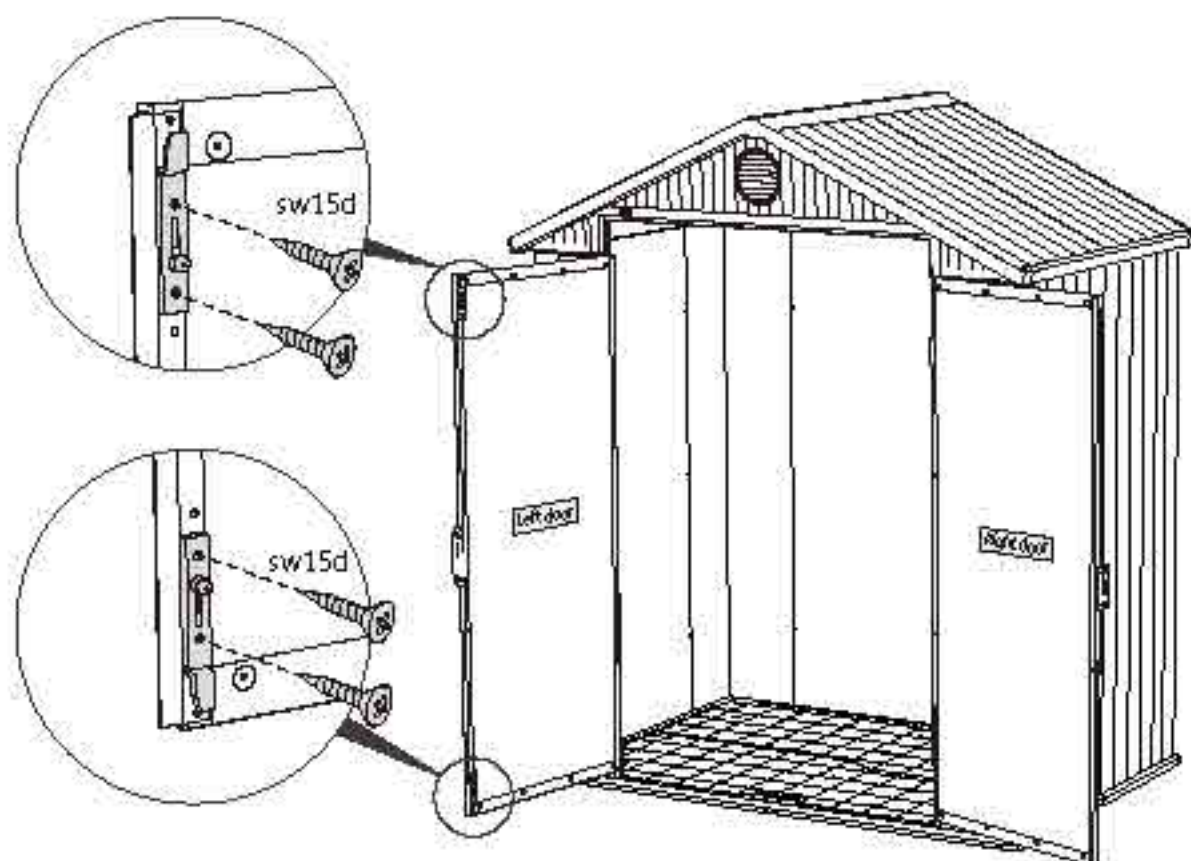
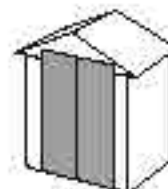

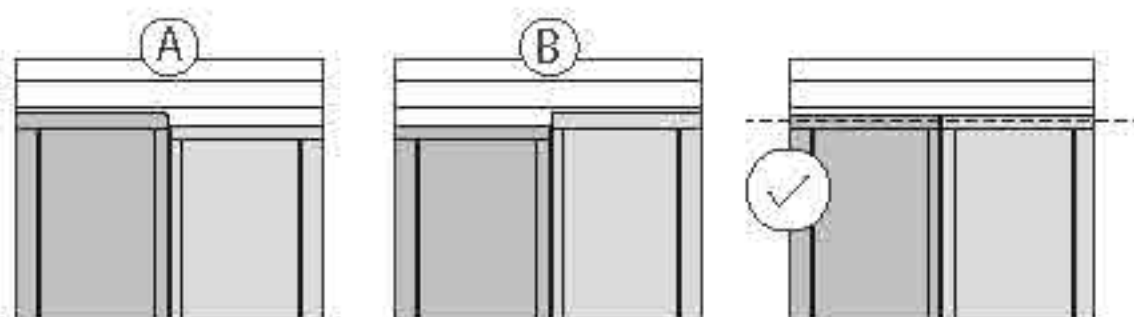

If you find that the shed is not level, use shims on either side of the shed or door | Si vous trouvez que votreabri n'est pas de niveau, mettez des cales sur chaque côté ou au niveau de la porte | Si usted encuentra que el cobertizo no está nivelado, utilice cuñas en ambos lados del cobertizo o en la puerta | Falls die Hütte nicht höhenleich sein sollte, verwenden Sie bitte Unterlegscheiben auf beiden Seiten der Hütte oder Tür | Als u merkt dat de schuur niet waterpas staat, gebruik dan vulplaten aan weerszijden van de schuur of deur | Nel caso in cui la casetta non dovesse essere in posizione orizzontale, usare degli spessori nella zona interessata | Se perceber que o armazém não está nivelado, use cuñas niveladoras em ambos os lados do armazém ou na porta

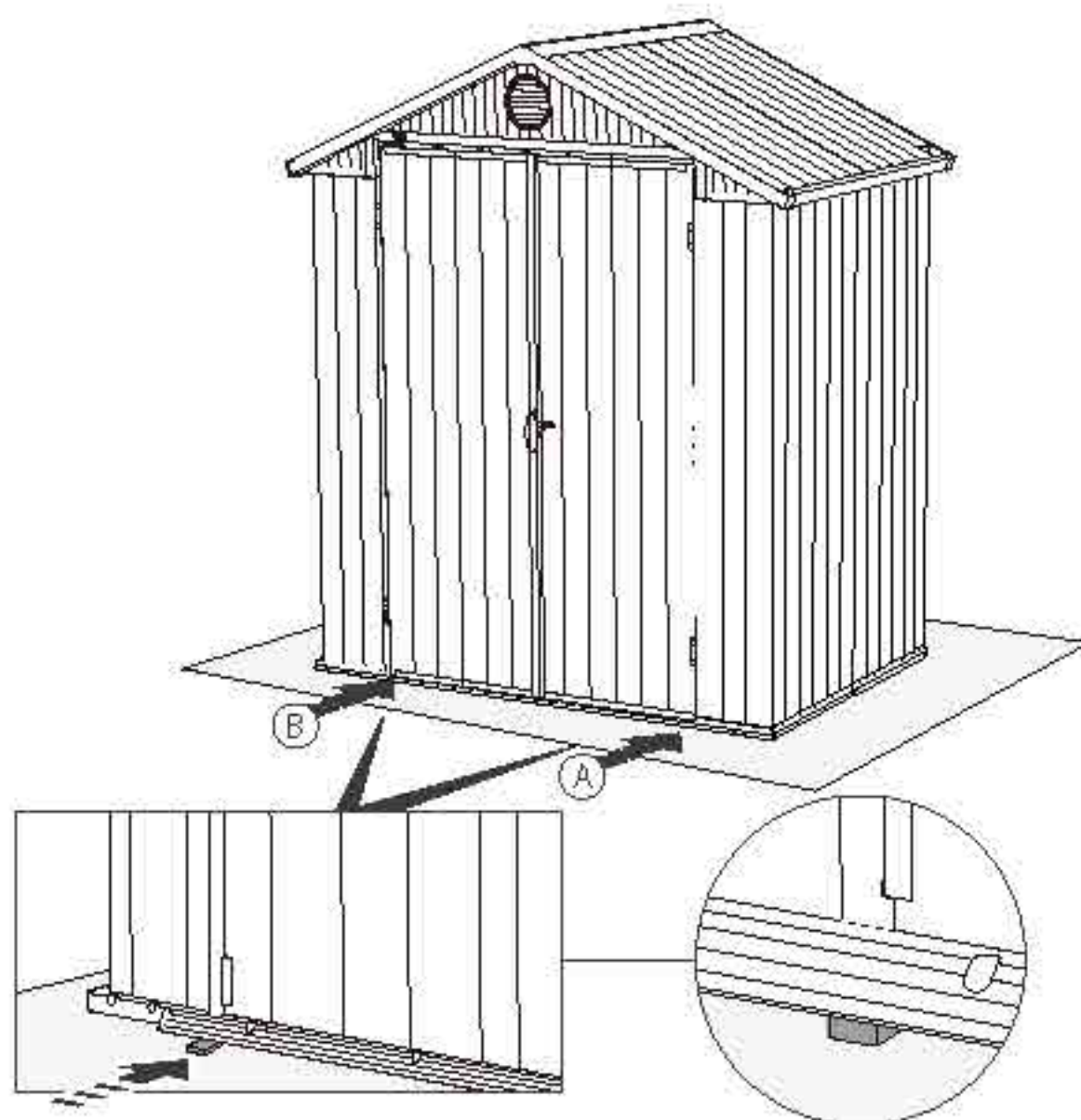

Securing the shed to a foundation

Affix the shed to the foundation by drilling holes in the shed floor at the pre-marked locations and screwing it into the foundation using appropriate screws (screws not included).

Fixer l'abri sur une fondation

Fixer l'abri à la fondation en perçant des trous dans le sol aux endroits pré-marqués et en insérant des vis adéquates dans la fondation (vis non fournies).

Asegurar el cobertizo a un cimiento

Fije el cobertizo a los cimientos perforando agujeros en el suelo del cobertizo en los lugares previamente marcados y atornillelo a los cimientos utilizando los tornillos adecuados (los tornillos no están incluidos).

Absichern des schuppens an ein fundament

Bringen Sie den Schuppen auf dem Fundament an, indem Sie an den Markierungen Löcher in den Schuppenboden bohren und diesen mit passenden Schrauben auf dem Fundament festschrauben (Schrauben nicht enthalten).

Het schuurtje op het fundament vastzetten

Bevestig het schuurtje aan de fundering door op de aangegeven plaatsen gaten te boren in de vloer van het schuurtje en het schuurtje aan de fundering te schroeven met behulp van passende schroeven (schroeven niet inbegrepen).

Assicurare la copertura alle fondamenta

Essai il deposito a terra alle fondamenta facendo dei fori nel pavimento nelle posizioni pre-segnalate ed avvitandolo alle fondamenta utilizzando apposite viti (viti non incluse).

Fixar o abrigo numa fundação

Afixe o abrigo à base abrindo buracos no chão nos locais previamente assinalados e apara fixando-o à mesma utilizando parafusos adequados (os parafusos não estão incluídos).

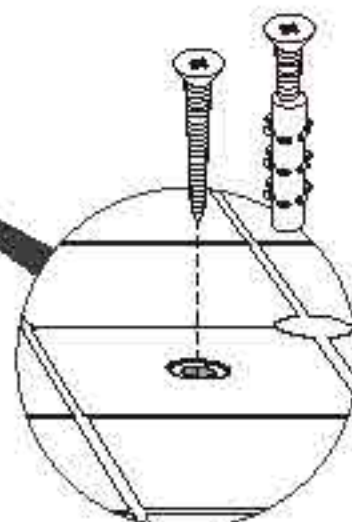
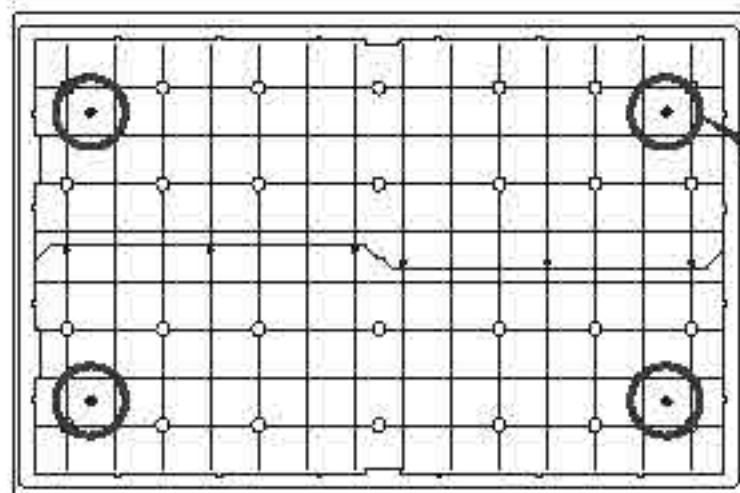
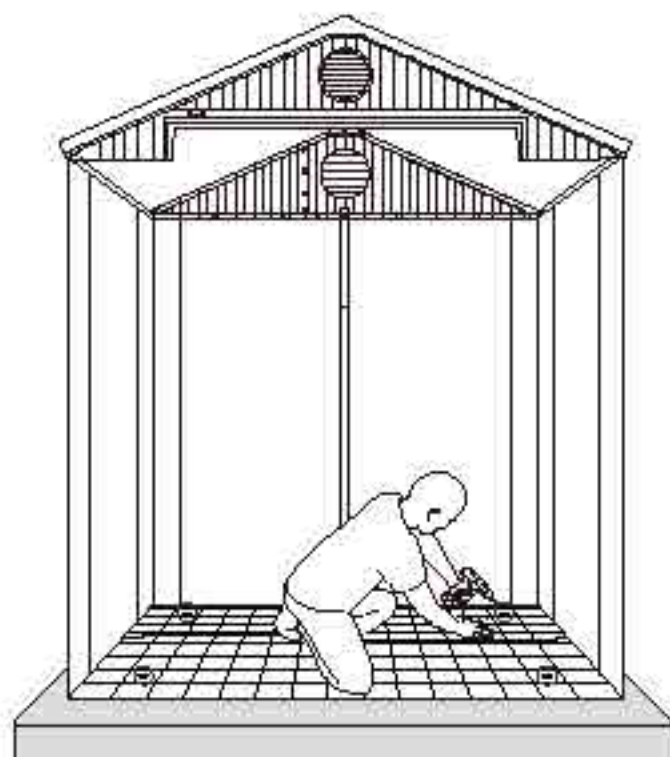

CARE AND SAFETY GUIDELINES

- The shed is intended for storage purposes only. It is not designed for habitation.
- It is strongly recommended to secure the shed to an immovable object or anchor to the ground by drilling holes in the shed floor (at the pre-marked locations) and inserting proper screws into the ground (screws are not included).
- Do not attempt assembly on windy or cold days.
- Periodically check the shed to ensure that it is stable and that the site is level.
- Be careful when handling parts with steel edges.
- When assembling or handling the shed, use only those tools listed in the user manual.
- Avoid using a lawnmower or mechanical scythe near the shed.
- Wear safety goggles and always follow the manufacturer's instructions when using power tools.
- Wash the shed with a garden hose or a mild detergent solution. Do not use a stiff brush or abrasive cleaners, including degreasers and oil- or acetone-based cleaning materials, as these may stain or damage the shed.
- Do not store hot items, such as recently used grills and blowtorches, and volatile chemicals in the shed.
- Avoid placing heavy items against the walls, as this may cause distortion.
- Keep the roof clear of accumulated snow and leaves. Large amounts of snow on the roof can damage the shed, making it unsafe to enter.
- Wind direction is an important factor to consider when determining the location of the shed. Reduce exposure to the wind, in general, and of the door side in particular. Keep doors closed and locked when the shed is not in use to prevent wind damage.
- Do not stand on the roof.
- Consult your local authorities to check if permits are required to erect the shed.

INSTRUCTIONS DE SÉCURITÉ ET D'ENTRETIEN

- L'abri a été conçu uniquement à des fins de stockage. Il n'a pas été conçu à des fins d'habitation.
- Il est fortement recommandé de sécuriser l'abri à un objet inamovible ou de le fixer au sol en creusant des trous dans le sol de l'abri (aux emplacements marqués) et d'insérer les vis adaptées dans le sol (vis non incluses).
- N'essayez pas de réaliser le montage par jour venteux ou froid.
- Vérifiez de temps en temps la tenue de l'abri afin de garantir sa stabilité et la mise à niveau du site, sur lequel il est posé.
- Manipulez les pièces présentant des bords en acier avec précaution.
- Lors de l'assemblage ou de la manipulation de l'abri, utilisez seulement les outils listés dans le mode d'emploi.
- Évitez d'utiliser une tondeuse à gazon ou une faucheuse mécanique à proximité de l'abri.
- Portez des lunettes de sécurité et suivez toujours les instructions du fabricant lors de l'utilisation d'outils électriques.
- Lavez l'abri à l'aide d'un tuyau d'arrosage de jardin ou d'un détergent non abrasif. N'utilisez pas une brosse dure ou de nettoyeurs abrasifs, y compris les dégraissants et les solutions de nettoyage à base d'acétone ou d'huile, car ils peuvent tacher ou endommager l'abri.
- Ne stockez pas d'objets chauds, tels qu'un grill ou un chalumeau récemment utilisé, ou des produits chimiques volatils dans l'abri.
- Évitez de placer des objets lourds contre les murs de votre abri, cela peut entraîner une déformation.
- Entretenez le toit pour éviter l'accumulation de neige ou de feuilles. Une grande quantité de neige sur le toit peut endommager l'abri, rendant périlleux l'accès à l'intérieur.
- La direction du vent est un facteur important à prendre en compte lors du choix de la localisation de l'abri. Réduisez l'exposition au vent, en général, et surtout pour le côté de la porte. Maintenez les portes fermées et verrouillées lorsque l'abri n'est pas utilisé, afin d'éviter tout dégât dû au vent.
- Ne montez pas sur le toit.
- Consultez les autorités de votre localité pour vérifier la nécessité de disposer d'un permis pour ériger l'abri.

ADVERTENCIA SOBRE EL CUIDADO Y LA SEGURIDAD

- La cobertizo está diseñada solo para el almacenamiento de productos. No está diseñada para habitar en ella.
- Se recomienda encarecidamente fijar la cobertizo a un objeto inamovible o anclarla al suelo taladrando agujeros en el suelo de la cobertizo (en los lugares premarcadas para ello), e insertando tornillos adecuados en el suelo (los tornillos no están incluidos).
- No intente montarlo en días de viento o cuando haga frío.
- Compruebe la cobertizo periódicamente para asegurarse de que es estable y de que el lugar es uniforme.
- Tenga cuidado al manejar las partes con bordes de acero.
- Al montar o manipular la cobertizo, use solamente las herramientas enumeradas en el manual del usuario.
- Evite usar un cortacésped o un cortacésped cerca de la cobertizo.
- Lleve gafas de seguridad y siga siempre las instrucciones del fabricante al utilizar herramientas eléctricas.
- Lave la cobertizo con una manguera de jardín o con un detergente suave.
- No utilice un cepillo rígido ni limpiadores abrasivos, incluyendo desengrasantes y materiales de limpieza basados en petróleo o acetona, ya que todos ellos pueden manchar o dañar la cobertizo.
- No guarde objetos calientes, como sopletes usados recientemente, ni elementos químicos volátiles.
- Evite situar objetos pesados contra las paredes, ya que esto puede causar deformación.
- Mantenga el techo limpio de nieve y hojas acumuladas. Una gran cantidad de nieve en el tejado puede dañar el cobertizo, haciendo que sea inseguro entrar.
- La dirección del viento es un factor importante a tener en cuenta al determinar la ubicación del cobertizo. Reduzca la exposición al viento en general y al lateral de la puerta en particular. Mantenga las puertas cerradas y bloqueadas cuando no utilice el cobertizo para evitar daños del viento.
- No se ponga de pie sobre el techo.
- Consulte con sus autoridades locales y son necesarios permisos para levantar el cobertizo.

PFLEGE - UND SICHERHEITSHINWEISE

- Der Gartenschuppen dient einzig und allein der Lagerung von Gegenständen. Der Schuppen ist nicht für Wohnzwecke ausgelegt.
- Es wird dringend empfohlen, den Schuppen an einem unbeweglichen Gegenstand zu befestigen oder Mithilfe von Löchern im Schuppenboden im Boden zu verankern (die Bohrungen müssen an den vorklassierten Stellen erfolgen), wobei geeignete Schrauben zu verwenden sind (Schrauben sind nicht im Lieferumfang enthalten).
- Führen Sie den Aufbau nicht an windigen oder kalten Tagen durch.
- Überprüfen Sie den Schuppen regelmäßig auf Stabilität und stellen Sie sicher, dass der Standort eben ist.
- Seien Sie vorsichtig, wenn Sie mit Teilen hantieren, die Stahlkanten aufweisen.
- Für Aufbau und Handhabung des Schuppens verwenden Sie bitte nur Werkzeuge, die in der Aufbauanleitung aufgelistet sind.
- Vermeiden Sie den Einsatz von Rasenmäher und maschineller Serie im direkten Umfeld des Schuppens.
- Tragen Sie eine Schutzhülle und befolgen Sie bei Verwendung von Elektrowerkzeugen immer die Anweisungen des Herstellers.
- Reinigen Sie den Schuppen mit einem Gartenschlauch und einem milden Reinigungsmittel. Verwenden Sie auf keinen Fall eine harte Bürste und Scheuer- oder Entfettungsmittel sowie öl- oder acetonalige Reinigungsmittel, da diese Flecken verursachen oder den Schuppen beschädigen könnten.

- Lagern Sie keine heißen Gegenstände im Schuppen, wie etwa kürzlich benutzte Grills oder Lötlampen, und auch keine flüchtigen Chemikalien.
- Lehnen Sie keine schweren Gegenstände an die Wände des Schuppens, da sich dadurch der gesamte Schuppen verziehen könnte.
- Halten Sie das Dach frei von Schnee und angesammeltem Blattwerk. Große Mengen an Schnee können den Schuppen beschädigen und beim Betreten gefährlich werden.
- Die Windrichtung ist ein wichtiger Faktor, der bei der Aufstellung des Schuppens unbedingt berücksichtigt werden muss. Vermeiden Sie zu hohe Windbelastungen, insbesondere einen hohen Winddruck auf die Türen. Halten Sie die Türen immer geschlossen und verriegelt, wenn der Schuppen nicht genutzt wird, um eine Beschädigung durch Windbelastungen zu vermeiden.
- Betreten Sie auf keinen Fall das Dach des Schuppens.
- Wenden Sie sich bitte an Ihre lokale Behörde und erkundigen Sie sich dort, ob zum Aufbau des Schuppens eine Genehmigung erforderlich ist.

RICHTLIJNEN VOOR ZORG EN VEILIGHEID

- Het tuinhuisje is uitsluitend bedoeld voor opslag. Het is niet ontworpen voor bewoning.
- Het wordt sterk aanbevolen om het tuinhuisje vast te maken aan een immobiel object of in de grond te verankeren door het boren van gaten in de vloer (op de gemarkeerde plaatsen) en het met de geschikte schroeven in de grond te bevestigen (schroeven zijn niet inbegrepen).
- Probeer niet op stormachtige of koude dagen te monteren.
- Controleer regelmatig of het tuinhuisje stabiel en waterpas staat.
- Wees voorzichtig als u werkt met onderdelen met staalranden.
- Gebruik bij de montage of het hanteren van het tuinhuisje alleen de gereedschappen die in de handleiding vermeld staan.
- Vermijd het gebruik van een gasmaaiër of mechanische zais in de buurt van het tuinhuisje.
- Draag een veiligheidshelm en volg altijd de instructies van de fabrikant als u elektrisch gereedschap gebruikt.
- Was het tuinhuisje met een tuinslang of een zacht schoonmaakmiddel. Gebruik geen harde borstel of schuurmiddelen, met inbegrip van ontvetters en schoonmaakmiddelen op basis van olie of aceton, omdat die het tuinhuisje kunnen beschadigen of vlekken achterlaten.
- Zet geen hete voorwerpen, zoals een pas gebruikte grill of branders in het tuinhuisje, en bewaar er ook geen vluchtige stoffen.
- Plaats geen zware voorwerpen tegen de wanden, die daardoor misvormd kunnen raken.
- Houd het dak vrij van opgehoopte sneeuw en bladeren. Grotere hoeveelheden sneeuw op het dak kunnen het tuinhuisje beschadigen, waardoor het betreden gevaarlijk kan zijn.
- De windrichting is een belangrijke factor bij het bepalen van de locatie van het tuinhuisje. Verminder blootstelling aan de wind, in het algemeen, en bijzonder aan de deurzijde. Houd de deuren gesloten en vergrendeld wanneer het tuinhuisje niet in gebruik is om windschade te voorkomen.
- Ga niet op het dak staan.
- Raadpleeg uw plaatselijke autoriteiten om te controleren of een vergunning vereist is voor het plaatsen van het tuinhuisje.

LINEE GUIDA PER LA CURA E LA SICUREZZA

- La casetta va utilizzata solo riporre oggetti. Non è progettata per abitanti.
- Si raccomanda vivamente di fissare la casetta ad un oggetto fisso o di ancorarla al suolo tramite i fori nel pavimento (nelle posizioni indicate) utilizzando viti adeguate (le viti non sono incluse).
- Non tentare l'assemblaggio in giornate ventose o fredde.
- Controllare periodicamente la casetta per accertarsi che sia stabile e ancorata al terreno.
- Prestare attenzione nel maneggiare i componenti in metallo.
- Durante l'assemblaggio della casetta, utilizzare solo gli strumenti elencati nel manuale utente.
- Evitare di utilizzare un tosaerba o una falce meccanica nei pressi della casetta.
- Indossare occhiali di sicurezza e seguire sempre le istruzioni del produttore nell'utilizzare utensili elettrici. • Lavare la casetta con acqua o con soluzione detergente delicata. Non utilizzare spazzole dure o detersivi abrasivi, né sgrassanti e materiali di pulizia a base d'olio, o a base di acetone, in quanto potrebbero macchiare o danneggiare la casetta.
- Non conservare oggetti caldi, come grill e fiamme ossidriche, né sostanze chimiche volatili nella casetta.
- Evitare di posizionare oggetti pesanti contro le pareti, in quanto potrebbero causare dei danni alla struttura.
- Mantenere il tetto pulito da neve e da cumuli di foglie. Grandi quantità di neve sul tetto potrebbero danneggiare la casetta, compromettendone la struttura.
- La direzione del vento è un fattore importante da considerare nella scelta della posizione della casetta. Ridurre il più possibile l'esposizione al vento, in particolare per la parte frontale. Tenere le porte chiuse con lucchetto quando la casetta non è in uso per prevenire possibili danni causati dal vento.
- Non salire sul tetto.
- Consultare le autorità locali per verificare la necessità di permessi per poter installare la casetta.

DIRETRIZES SOBRE CUIDADOS E SEGURANÇA

- O abrigo destina-se apenas a fins de armazenamento. Não foi projetado para habitação.
- Recomenda-se vivamente a fixação do abrigo a um objeto imóvel ou fixá-lo no chão fazendo furos no piso do abrigo (nos locais previamente marcados) e a inserção de parafusos adequados no chão (os parafusos não estão incluídos).
- Não tente fazer a montagem em dias ventosos ou frios.
- Verifique periodicamente o abrigo para garantir que está estável e que o sítio está nivelado.
- Tenha cuidado ao manusear peças com pontas em aço.
- Ao montar ou manipular o abrigo, utilize apenas as ferramentas indicadas no manual do utilizador.
- Evite a utilização de um cortador de relva ou fôrças mecânicas perto do abrigo.
- Use óculos de segurança e siga sempre as instruções do fabricante ao utilizar ferramentas elétricas.
- Lave o abrigo com uma mangueira de jardim ou uma solução de detergente suave. Não use uma escova rija ou detergentes abrasivos incluindo desengordurantes ou materiais de limpeza com base de óleo ou acetona, visto que estes podem manchar ou danificar o abrigo.
- Não guarde artigos quentes, como grelhas e maçaricos recentemente utilizados, e químicos voláteis no abrigo.
- Evite a colocação de artigos pesados contra as paredes, visto que isto pode causar distorção.
- Mantenha o telhado livre de acumulação de neve e folhas. Grandes quantidades de neve no telhado podem danificar o abrigo, tornando-o inseguro para entrar.
- A direção do vento é um fator importante a ter em consideração ao determinar a localização do abrigo. Reduza a exposição ao vento, em geral, e em particular da porta lateral. Mantenha as portas fechadas e trancadas quando o abrigo não estiver a ser utilizado para evitar danos causados pelo vento.
- Não fique no telhado.
- Consulte as autoridades locais para saber se são necessárias licenças para erguer o abrigo.

10-YEAR LIMITED WARRANTY

Your Keter shed ("the Product") was manufactured from high-quality, recyclable materials under rigorous control and supervision.

Should a problem occur with the Product, please address your claim to Keter customer service on our website (www.keter.com) or by phone.

This warranty covers product failure resulting from defects in manufacturing or materials for a period of 10 years from the date of original retail purchase. (The term "defect" is defined as imperfections that impair the use of the Product.)

This warranty does not cover defects resulting from normal wear and tear, including, but not limited to, scuffing, scratches or fractures caused during use, discoloration or fading, rusting, unreasonable use, abuse, negligence, alterations, painting, moving, transporting or relocating the Product, "acts of Nature," including, but not limited to, hail, any type of storm, flood and fire, and consequential or incidental damages.

Assembly and handling not in accordance with the recommendations, guidelines and restrictions as described in the Product's user manual, and usage for commercial or public applications, will void this warranty.

Keter is not responsible for any damage incurred by third parties or damage to or loss of objects inside or near the shed.

Upon submitting proof of purchase and evidence of the claimed product failure, and subject to reporting the failure in a timely manner, Keter, at its sole discretion, will replace defective parts of the Product, or refund you a prorated portion of the purchase price on a straight-line depreciated basis for the length of the warranty.

GARANTIE LIMITÉE DE 10 ANS

Votre abri de jardin Keter ("le Produit") a été fabriqué à partir de matériaux recyclables de grande qualité, en faisant l'objet de contrôles rigoureux et d'une surveillance stricte.

Si un problème devait se présenter avec le produit, veuillez adresser votre réclamation au service client de Keter sur notre site internet (www.keter.com) ou par téléphone.

Cette garantie couvre les dommages du produit découlant d'un défaut de fabrication ou des matériaux pendant une durée de 10 ans à partir de la date d'achat. (Le terme "défaut" est défini comme des imperfections qui nuisent à la bonne utilisation du produit.)

Cette garantie ne couvre pas les défauts résultant d'une usure normale, y compris, mais non limitée aux rayures, aux éraflures ou aux bris provoqués par l'utilisation, la décoloration ou l'estompage de la couleur, la rouille, l'utilisation déraisonnable, les abus, la négligence, les altérations, la peinture, les déplacements, le transport ou la relocalisation du produit, les "conditions climatiques exceptionnelles", y compris, mais non limitée à la grêle, tout type de tempête, les inondations et incendies, et tous dégâts accidentels ou consécutifs qui y seraient liés.

Un assemblage et une manipulation non conformes aux recommandations, aux instructions et aux restrictions, telles que décrites dans le mode d'emploi du Produit, ainsi que l'utilisation à des fins commerciales ou publiques, annuleront cette garantie.

Keter ne saurait être tenu responsable de tout dégât en ou sur une tierce partie ou de tout dégât ou perte d'objets à l'intérieur ou à proximité de l'abri.

Après avoir soumis une preuve d'achat et une preuve du dommage sur le produit détérioré, et à condition d'avoir signalé le dommage dans les délais impartis, Keter, à son absolue discrétion, remplacera les pièces défectueuses du Produit ou vous remboursera une partie du prix d'achat au prorata, amorti sur une base linéaire pour la durée de la garantie.

GARANTÍA LIMITADA DE 10 AÑOS

Su caseta Keter ("El Producto") ha sido fabricada con materiales reciclables de alta calidad bajo rigurosos controles y supervisión.

En caso de que aparezca un problema con el Producto, por favor, dirija su reclamación al servicio al cliente de Keter en nuestra página web (www.keter.com) o por teléfono.

Esta garantía cubre errores fallos de producto por defectos de fabricación o de materiales durante un periodo de 10 años desde la fecha de la compra del producto. (El término "defectos" se define como imperfecciones que afectan al uso del Producto).

Esta garantía no cubre defectos resultantes por el desgaste debido al uso, incluyendo, entre otros, arañazos, rasguños o roturas provocados durante su uso, decoloración, oxidación, uso no razonable, maltrato, negligencia, alteraciones, pintado, mover, transportar o reubicar el Producto, "causas climatológicas", incluyendo, entre otros, granizo, cualquier tipo de tormenta, inundación e incendio y daños resultantes o accidentales.

El montaje y su manipulación sin seguir las recomendaciones, directrices y restricciones como se describen en el manual del usuario del Producto y su uso para aplicaciones comerciales o públicas anularán esta garantía.

Keter no se hace responsable por ningún daño realizado por terceros o daños o pérdida de objetos dentro o cerca de la caseta.

Al entregar el ticket o factura de compra y prueba del presunto fallo del producto, y sujeto a informar del fallo de manera puntual, Keter, a su discreción, reemplazará las piezas defectuosas del Producto o le reembolsará una parte prorrateada proporcional del precio de compra en función de los años de garantía consumidos.

AUF 10 JAHRE BEGRENZTE GEWÄHRLEISTUNG

Ihr Keter-Schuppen („das Produkt“) wurde unter genauer Kontrolle und strenger Aufsicht aus hochwertigen und recycelbaren Materialien hergestellt.

Falls Probleme am Produkt auftauchen sollten, adressieren Sie Ihre Ansprüche bitte an den Keter-Kundendienst auf unserer Webseite (www.keter.com) oder wenden Sie sich per Telefon an uns.

Die auf 10 Jahre begrenzte Gewährleistung umfasst Herstellungs- oder Materialdefekte am Produkt und gilt ab dem Datum des ursprünglichen Erwerbs. (Der Begriff „Defekte“ wird definiert als Beeinträchtigungen, die die Nutzung des Produktes herabsetzen).

Diese Gewährleistung umfasst keine Defekte, die aus normalem Gebrauch resultieren und schließen unter anderem durch die Nutzung des Produktes entstandenen Abrieb, Kratzer oder Risse mit ein sowie Verfärbungen, Rostansatz und Schäden aufgrund von unsachgemäßer Nutzung, Missbrauch, Unachtsamkeit, Abänderungen, Bemalen, das Versetzen oder Transportieren des Produktes und „Naturereignisse“, wozu unter anderem Hagelschlag, jegliche Form von Sturm, Flut und Feuer zählen sowie mittelbare und damit verbundene Beschädigungen hierdurch.

Bei Aufbau und Handhabung, die nicht gemäß den Empfehlungen, Vorgaben und Beschränkungen durchgeführt werden, wie sie in der Gebrauchsanleitung zu dem Produkt vermerkt sind, verliert diese Gewährleistung ihre Gültigkeit. Dies gilt auch für einen Gebrauch zu kommerziellen und öffentlichen Zwecken.

Keter ist nicht verantwortlich für Beschädigungen durch Dritte und Schäden an und Verlust von Gegenständen innerhalb oder in der Nähe des Schuppens.

Nach der Einreichung von Kaufnachweis und Beweismaterial für den beanspruchten Defekt am Produkt, vorbehaltlich einer zeitnahen Meldung des Defekts, wird Keter während der gesamten Gewährleistungsdauer nach alleinigem Ermessen fehlerhafte Teile austauschen oder einen anteiligen Betrag des Kaufpreises auf Basis der linearen Abschreibung zurückerstatten.

10-JAAR BEPERKTE GARANTIE

Uw Keter tuinhuisje ("het product") is vervaardigd uit hoogwaardige en recyclebare materialen, onder strenge controle en toezicht.

Mocht zich een probleem voordoen met het product, kunt u uw claim naar de klantendienst van Keter sturen via onze website (www.keter.com) of per telefoon. Deze garantie dekt het product voor gebreken in de productie of materialen voor een periode van 10 jaar vanaf de datum van de oorspronkelijke aankoop. (De term "gebreken" wordt gedefinieerd als onvolkomenheden die het gebruik van het product schaden).

Deze garantie geldt niet voor defecten die het gevolg zijn van normale slijtage, met inbegrip van, maar niet beperkt tot, schuren, krassen of breuken ontstaan tijdens het gebruik, verkleuring of vervaging van de kleuren, roest, onredelijk gebruik, misbruik, nalatigheid, wijzigingen, verven, vervoeren of verplaatsen van het product, "natuurlijke calamiteiten," met inbegrip van, maar niet beperkt tot, hagel, elke vorm van storm, overstroming en brand, en gevolg- of incidentele schade.

Bij assemblage en behandeling niet in overeenstemming met de aanbevelingen, richtlijnen en beperkingen zoals beschreven in de gebruiksaanwijzing van het product, en gebruik voor commerciële of publieke toepassingen, vervalt deze garantie.

Keter is niet verantwoordelijk voor enige schade opgelopen door derden of schade aan of verlies van objecten binnen of in de buurt van het tuinhuisje.

Door het indienen van het aankoopbewijs en het bewijs van het geclaimde gebrek aan het product, en onder voorbehoud van een tijdige rapportage van de gebreken, zal Keter, naar eigen goeddunken, defecte onderdelen van het product vervangen of een pro rata deel van de koopprijs terugbetalen van op basis van een lineair afgeschreven bedrag over de duur van de garantie.

10 ANNI DI GARANZIA

La casetta da giardino Keter ("il Prodotto") è realizzata con materiali riciclabili di alta qualità sotto un controllo ed una supervisione rigorosi. In caso di problemi con il prodotto, cortesemente rivolgetevi al servizio clienti Keter sul nostro sito web (www.keter.com) o per telefono. La garanzia copre problematiche dovute a difetti di fabbricazione o dei materiali per un periodo di 10 anni dalla data di acquisto originale. (Il termine "difetti" è definito come imperfezioni che compromettono l'uso del prodotto). Questa garanzia non copre i difetti derivanti da normale usura, inclusi, ma non limitati a, sfregamento, graffi o fratture creati durante l'uso, scolorimento, ruggine, uso irragionevole, abuso, negligenza, alterazione, verniciatura, movimentazione, trasporto o spostamento del prodotto, "eventi naturali", tra cui, ma non limitati a, grandine, qualsiasi tipo di tempesta, inondazioni, incendi e danni conseguenti o accidentali. L'assemblaggio e la manipolazione non in conformità con le raccomandazioni, le linee guida e le restrizioni descritte nel manuale utente del prodotto ed il loro utilizzo per applicazioni commerciali o pubbliche renderà nulla questa garanzia. Keter non è responsabile per eventuali danni subiti dal consumatore e/o terzi o per danni e smarrimenti di oggetti all'interno o nei pressi della casetta. Dopo aver inviato la prova di acquisto, la prova del problema del prodotto e una dichiarazione tempestiva del problema, Keter, a sua esclusiva discrezione, sostituirà le parti difettose del prodotto, o rimborserà una parte proporzionale del prezzo di acquisto rispetto al valore residuo del prodotto, che si deprezerà proporzionalmente durante il periodo di garanzia.

GARANTIA LIMITADA DE 10 ANOS

O seu abrigo Keter ("o Produto") foi fabricado manualmente a partir de materiais recicláveis de qualidade superior sob controle e supervisão rigorosos.

Em caso de ocorrência de algum problema com o Produto, por favor, faça a sua reclamação para o serviço de apoio ao cliente Keter no nosso site (www.keter.com) ou por telefone.

Esta garantia cobre falhas do produto resultantes de defeitos de fabrico ou materiais durante um período de 10 anos a partir da data da compra a retalho original. (O termo "defeitos" é definido como imperfeições que comprometeram a utilização do Produto).

Esta garantia não cobre defeitos resultantes da utilização e desgaste normais, incluindo, mas não limitado a, fricção, arranhões ou faturas causadas durante a utilização, descoloração ou desbotamento, oxidação, utilização pouco razoável, abuso, negligência, modificações, pintura, deslocação, transporte ou reposicionamento do Produto, "atos da Natureza", incluindo, mas não limitado a, granizo, qualquer género de tempestade, inundações e incêndio, e danos consequentes ou accidentais.

A montagem e manipulação que não estejam em conformidade com as recomendações, diretrizes e restrições de acordo com o descrito no manual do utilizador do Produto, e a utilização para finalidades comerciais ou públicas, anularão esta garantia.

A Keter não se responsabiliza por quaisquer danos incorridos por terceiros ou danos e perdas dentro ou perto do barracão.

Mediante a apresentação do comprovativo de compra e prova da falha do produto reclamado, e sujeito a reportar a falha do produto a tempo, a Keter, ao seu critério exclusivo, irá proceder à substituição das partes defeituosas do Produto, ou reembolsá-lo com uma parcela proporcional ao preço de compra numa base de amortização linear relativa à duração da garantia.

IF THERE ARE MISSING OR BROKEN PARTS, PLEASE DO NOT RETURN THE PRODUCT TO THE STORE.
PLEASE ACCESS OUR WEBSITE WWW.KETER.COM, OR CONTACT CUSTOMER SERVICE AT YOUR COUNTRY/REGION:

SI L Y A DES PIÈCES MANQUANTES OU CASSÉES, NE RETOURNEZ PAS LE PRODUIT AU MAGASIN.
VEUILLEZ ACCÉDER À NOTRE SITE WEB WWW.KETER.COM OU CONTACTER LE SERVICE CLIENT DE VOTRE PAYS/RÉGION:

SI HUBIERA ALGUNA PARTE FALTANTE O DAÑADA, NO DEVUELVA EL PRODUCTO A LA TIENDA.
ACCEDA A NUESTRA WEB WWW.KETER.COM O CONTACTO CON EL SERVICIO DE ATENCIÓN AL CLIENTE DE SU PAÍS/REGIÓN:

BITTE BRINGEN SIE IHR PRODUKT NICHT GLEICH ZUM LADEN ZURÜCK, FALLS TEILE FEHLEN ODER DEFEKT SIND.
BITTE LOGGEN SIE IN UNSERE WEBSITE EIN ODER WENDEN SIE SICH AN UNSEREN KUNDENSERVICE:

IN GEVAL VAN ONTBREKENDE OF BESCHADIGDE ONDERDELEN KUNT U GEBRUIK MAKEN VAN DE KETER ONDERDELENSERVICE
GA NAAR ONZE WEBSITE WWW.KETER.COM OF NEEM CONTACT OP MET DE KLANTENSERVICE VIA ONDERSTAANDE
CONTACTGEGEVENS:

IN CASO DI PARTI MANCANTI O ROTTE, PREGHIAMO DI NON RESTITUIRE IL PRODOTTO AL NEGOZIO.
CHIEDIAMO CORTESEMENTE DI ACCEDERE AL NOSTRO SITO WEB WWW.KETER.COM O, CONTATTARE IL SERVIZIO CLIENTI DEL
VOSTRO PAESE:

SE EXISTER EM PEÇAS DANIFICADAS OU PARTIDAS POR FAVOR NÃO EFECTUAR DEVOLUÇÃO À LOJA.
ACEDA AO NOSSO SITE WWW.KETER.COM OU AO NOSSO SERVIÇO DE PÓS VENDA:

US/Canada: (en) en
keter.com/en-us/contact-us.html
Tel: +1-888-374-4262
Email: NACS@keter.com

UK: (en) en
Tel: +44-121-505-0008
Email: CSUK@keter.com
Keter UK Ltd
16 Great Queen Street, Covent
Garden, London, WC2B 5AH
Mon - Fri | 9am - 4pm

Israel:
Tel: 1-700-70-6015

Switzerland:
Tel: +41-62-767-00-90
Email: info@neogard.ch

France:
Votre produit ayant été acheté dans
une enseigne, quelle soit physique ou
sur internet, c'est auprès de cette
enseigne que vous devez faire votre
demande SAV.

Australia:
Tel: 03-9544-6399
Email: keteraus@keter.com
28 Buzland St,
Clayton, Victoria 3168
Mon - Fri | 9am - 5pm

Iberia:
Email: spk@keter@corcasba.com

South Africa:
Email: info@keter.co.za

Spain: (es) es
Tel: +34-949-277-421
Email: spk@keter@corcasba.com
Avenida Conde de Romanones 6-b,
Polg. Ind. Miralcampo,
15000 Azuqueca de Henares -
Guadalajara, Spain
Mon - Fri | 9am - 7pm

Italy:
Tel: +39-0422-745900
Email: Servizio.clienti@keter.com

고객센터:
Tel: 051-767-2432
Email: info@keter.co.kr
월 - 금 | 9:00am - 05:30pm

Poland:
Tel: +48-5984-19-892
Email: Servicepoland@keter.com

Hungary:
Tel: +36-52-565520
Email: Servicehungary@keter.com

Nordics:
Tel: +48-5984-19-892
Email: Service nordic@keter.com

Germany/Austria:
Tel: +49(3)222-10-9542-1
Email: service@keter-austria.de

NL/BE/LUX:
Email: klantenservice@keter.com

WWW.KETER.COM



KETER
Le développement durable au
quotidien | Sostenibilidad día a día



Designed to Last | Conçu pour durer | Diseñado
para durar | Auf Langlebigkeit ausgelegt |
Duurzaam ontworpen | Progettato per durare |
Projektado para durar

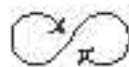

Recyclability | Recycling | Recyclabilité et
Recyclage | Reciclabilidad y reciclable | recycling
| Reciclaat | Recyclabiliteit | Recycling |
Reciclabilità | Riciclo | Reciclabilidad y Reciclaje



Community | Communauté |
Comunidad | Community |
Comunidade | Comunità | Comunidade



Responsible Manufacturing | Fabrication responsable
Producción responsable | Verantwoordingsbewuste
Herstelling | Verantwoorde productie |
Produzione responsabile | Fabricação responsável

Made in Israel by | Fabriqué en Israël par | Fabricado en Israel por | Hergestellt in Israel von | Gemaakt in Israël door |
Realizzato in Israele da | Fabricado em Israel por Keter Home and Garden Products Ltd, 1 Sapir St. Industrial Area,
Herdiya 4685205, Israel



KETER